

Bohrungen drehen

Geeignet ab Bohrungsdurchmesser 3,2 mm.

Boring

For use in bores as of minimum bore diameter 3,2 mm.

Schnittwerte (Start) // Cutting parameters (start)

f	Vc
0,02 mm/U	Seite/Page 429

Passende Klemhalter auf Seite // Suitable toolholders on page

26, 27, 31, 32, 33, 34, 35, 40, 41, 43, 44, 50, 51, 53, 55, 56, 57, 60, 61, 62, 63, 65, 66, 67, 68, 69



Legende Legend **139**

Scan QR-Code Oder besuchen Sie // Or Visit www.simtek.info/cp/754



Abbildung zeigt / Drawing shows: A05.9025.15.52.20 Y R



Mehr Informationen zur Kühlmittelzufuhr finden Sie auf Seite 22
Additional information about through coolant supply on page 22

ØD	L2	ØDmin (Min. Bohrung) ØDmin (min. bore)	R	Kühlmittelzufuhr Through coolant supply	Artikelnummer Part number	Webcode www.simtek.com/webcode	Unsere erste Wahl Our first choice	a	d	f	LH	tmax	Connectcode www.simtek.com/code
mm	mm	mm	mm				P K M N S	mm	mm	mm	mm	mm	
▼ ØDmin (Min. Bohrung) // ØDmin (min. bore) = 3,2 mm													
4,0	12,2	3,2	0,15	+	A04.9015.12.32.15 YR/L	R APB9 L ADVC	X800 X400	2,95	2,55	1,45	15,0	0,2	R A04.R L A04.L
▼ ØDmin (Min. Bohrung) // ØDmin (min. bore) = 4,2 mm													
4,0	15,2	4,2	0,15	+	A04.9020.15.42.15 YR/L	R APXB L ANKP	X800 X400	3,95	3,45	1,95	18,0	0,3	R A04C.R L A04C.L
▼ ØDmin (Min. Bohrung) // ØDmin (min. bore) = 5,2 mm													
5,0	10,2	5,2	0,2	+	A05.9025.10.52.20 YR/L	R AJ84 L AHEC	X800 X400	4,95	4,2	2,45	13,0	0,5	R A05.R L A05.L
5,0	15,2	5,2	0,2	+	A05.9025.15.52.20 YR/L	R AHSM L AKCD	X800 X400	4,95	4,2	2,45	18,0	0,5	R A05.R L A05.L
5,0	20,3	5,2	0,2	+	A05.9025.20.52.20 YR/L	R AM84 L AJSE	X800 X400	4,95	4,2	2,45	23,0	0,5	R A05.R L A05.L

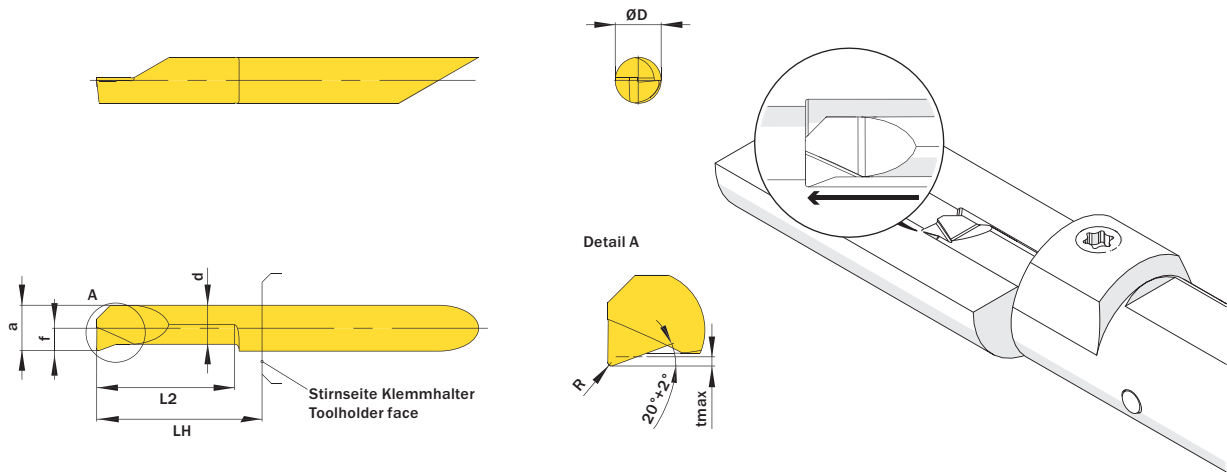
Bestellbeispiel // Order example: **A04.9015.12.32.15 YR X800** (R = Rechte Ausführung // Right hand version, X800 = Schneidstoff // Grade)