

# Ausdrehen

Geeignet ab Bohrungsdurchmesser 2,2 mm.

# Boring

For use in bores as of minimum bore diameter 2,2 mm.

Schnittwerte (Start) // Cutting parameters (start)

f	Vc
0,02 mm/U	Seite/Page 429

Passende Klemmhalter auf Seite // Suitable toolholders on page

26, 31, 32, 33, 34, 40, 41, 43, 50,  
51, 53, 55, 56, 57, 60, 62, 63, 65,  
66, 67, 68, 69

Vergleichbare Werkzeuge auf Seite // Similar tools on page

70



Legende  
Legend 139

Scan QR-Code Oder besuchen Sie // Or Visit  
www.simtek.info/cp/1038

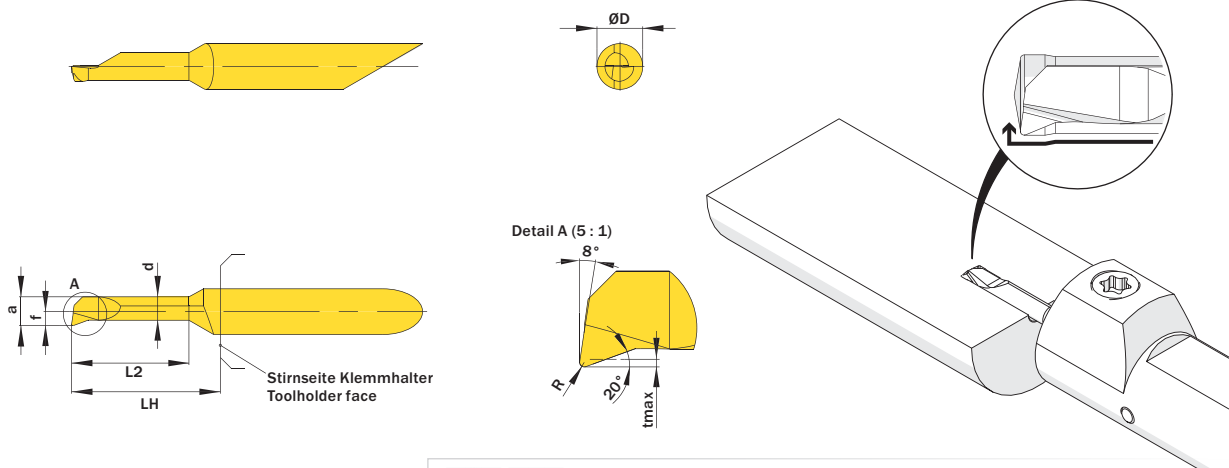

Mehr Informationen zur Kühlmittelzufuhr finden Sie auf Seite 22  
Additional information about through coolant supply on page 22

ØD	L2	ØDmin (Min. Bohrung) ØDmin (min. bore)	R	Kühlmittelzufuhr Through coolant supply	Artikelnummer Part number	Webcode www.simtek.com/webcode	Unsere erste Wahl Our first choice	a	d	f	LH	tmax	Connectcode www.simtek.com/code
mm	mm	mm	mm				P K M N S	mm	mm	mm	mm	mm	

Fortgesetzte Tabelle  
Continued Table

Verwandte Werkzeuge finden Sie auch auf der vorhergehenden Seite!  
Related Items can be found on the previous page as well!

4,0	6,1	2,2	0,05	●	A04.1810.06.22.05 YR/L	R AEWA L AHNE	X800 X400	1,95	1,55	0,95	13,0	0,2	R A04.R L A04.L
4,0	6,1	2,2	0,05	+	A04.1C10.06.22.05 YR/L	R AW9M L AXAF	X800 X400	1,95	1,55	1,95	13,0	0,2	R A04C.R L A04C.L
4,0	6,1	2,2	0,1	●	A04.1810.06.22.10 YR/L	R AMKG L ABK2	X800 X400	1,95	1,55	0,95	13,0	0,2	R A04.R L A04.L
4,0	6,1	2,2	0,1	+	A04.1C10.06.22.10 YR/L	R ABCM L AKQQ	X800 X400	1,95	1,55	1,95	13,0	0,2	R A04C.R L A04C.L
4,0	9,1	2,2	0,05	●	A04.1810.09.22.05 YR/L	R AFEA L AEVE	X800 X400	1,95	1,55	0,95	13,0	0,2	R A04.R L A04.L
4,0	9,1	2,2	0,05	+	A04.1C10.09.22.05 YR/L	R AW9N L AXAG	X800 X400	1,95	1,55	1,95	13,0	0,2	R A04C.R L A04C.L
4,0	9,1	2,2	0,1	●	A04.1810.09.22.10 YR/L	R AM4S L AA7F	X800 X400	1,95	1,55	0,95	13,0	0,2	R A04.R L A04.L
4,0	9,1	2,2	0,1	+	A04.1C10.09.22.10 YR/L	R ABD9 L AMX3	X800 X400	1,95	1,55	1,95	13,0	0,2	R A04C.R L A04C.L
4,0	13,2	2,2	0,1	●	A04.1810.13.22.10 YR/L	R AKP9 L AJ36	X800 X400	1,95	1,55	0,95	18,0	0,2	R A04.R L A04.L
4,0	13,2	2,2	0,1	+	A04.1C10.13.22.10 YR/L	R AGGH L AEBZ	X800 X400	1,95	1,55	1,95	18,0	0,2	R A04C.R L A04C.L
4,0	15,2	2,2	0,1	+	A04.1C10.15.22.10 YR	A2AB	X800 X400	1,95	1,55	1,95	23,0	0,2	A04C.R
▼ ØDmin (Min. Bohrung) // ØDmin (min. bore) = 2,7 mm													
4,0	10,2	2,7	0,03	●	A04.1812.10.27.03 YR/L	R AKG6 L AHF1	X800 X400	2,45	2,05	1,2	13,0	0,2	R A04.R L A04.L
4,0	10,2	2,7	0,03	+	A04.1C12.10.27.03 YR/L	R AW9P L AXAH	X800 X400	2,45	2,05	1,95	13,0	0,2	R A04C.R L A04C.L
4,0	10,2	2,7	0,05	●	A04.1812.10.27.05 YR/L	R AFXD L AFVH	X800 X400	2,45	2,05	1,2	13,0	0,2	R A04.R L A04.L
4,0	10,2	2,7	0,05	+	A04.1C12.10.27.05 YR/L	R AW9Q L AXAJ	X800 X400	2,45	2,05	1,95	13,0	0,2	R A04C.R L A04C.L
4,0	10,2	2,7	0,15	●	A04.1812.10.27.15 YR/L	R AH2M L ACX1	X800 X400	2,45	2,05	1,2	13,0	0,2	R A04.R L A04.L
4,0	10,2	2,7	0,15	+	A04.1C12.10.27.15 YR/L	R AJ8J L AJ01	X800 X400	2,45	2,05	1,95	13,0	0,2	R A04C.R L A04C.L
4,0	15,2	2,7	0,05	●	A04.1812.15.27.05 YR/L	R ANPQ L AEK2	X800 X400	2,45	2,05	1,2	18,0	0,2	R A04.R L A04.L
4,0	15,2	2,7	0,05	+	A04.1C12.15.27.05 YR/L	R AW9S L AXAK	X800 X400	2,45	2,05	1,95	18,0	0,2	R A04C.R L A04C.L
4,0	15,2	2,7	0,15	●	A04.1812.15.27.15 YR/L	R AA95 L AJKP	X800 X400	2,45	2,05	1,2	18,0	0,2	R A04.R L A04.L
4,0	15,2	2,7	0,15	+	A04.1C12.15.27.15 YR/L	R AB8C L AAQ1	X800 X400	2,45	2,05	1,95	18,0	0,2	R A04C.R L A04C.L
4,0	20,3	2,7	0,15	+	A04.1C12.20.27.15 YR	A2AC	X800 X400	2,45	2,05	1,95	28,0	0,2	A04C.R

Verwandte Werkzeuge finden Sie auch auf der folgenden Seite!  
Related Items can be found on the following page as well!

Fortgesetzte Tabelle  
Continued Table

Bestellbeispiel // Order example: A04.1812.10.27.15 YR X800 (R = Rechte Ausführung // Right hand version, X800 = Schneidstoff // Grade)