

# Klemmhalter, Innenbearbeitung

Schwingungsgedämpfter Hartmetall-Rundschaft mit innerer Kühlmittelzufuhr.

## Toolholder, For Internal Applications

Anti-vibration solid carbide round shank toolholder with through coolant.

Anzugsmoment (Schraube) // Tightening torque (screw)

**2,1 Nm**

Bitte Hinweise im Anhang beachten // Please read add. notes

**MASTER (Seite/Page 212)**



Legende  
Legend **213**



Scan  
QR-Code

Oder besuchen Sie // Or Visit  
[www.simtek.info/cp/810](http://www.simtek.info/cp/810)

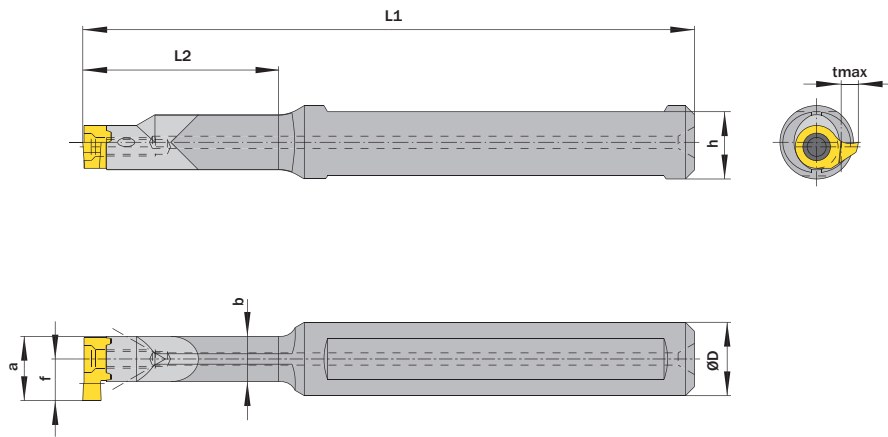

Maße „a“, „f“ und „tmax“ sind abhängig vom verwendeten Schneideinsatz.  
Dimensions „a“, „f“ and tmax depend on used carbide inserts.

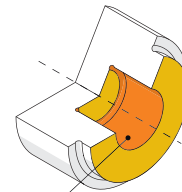

- Hauptsächlich geeignet für diese Flächen  
Mainly designed for these surfaces
- Je nach Schneidplatte ebenfalls möglich  
Also possible depending on insert type

<b>ØD</b> <sup>h6</sup>	<b>L2</b>	Artikelnummer Part number	<b>Webcode</b> <a href="http://www.simtek.com/webcode">www.simtek.com/webcode</a>	<b>b</b>	<b>h</b>	<b>L1</b>	Schraube Screw	Schraubenschlüssel Screw driver	<b>Connectcode</b> <a href="http://www.simtek.com/code">www.simtek.com/code</a>
mm	mm			mm	mm	mm			

◀ Fortgesetzte Tabelle  
Continued Table

Verwandte Werkzeuge finden Sie auch auf der vorhergehenden Seite!  
Related Items can be found on the previous page as well!

12,0	24,0	<b>D10.0012.24 HM</b>	AKMV	7,4	11,0	92,0	D M3x9 T9F	T9F	D10	
12,0	32,0	<b>D10.0012.32 HM</b>	AJJ7	7,4	11,0	100,0	D M3x9 T9F	T9F	D10	
12,0	48,0	<b>D10.0012.48 HM</b>	AHP2	7,4	11,0	115,0	D M3x9 T9F	T9F	D10	
12,0	64,0	<b>D10.0012.64 HM</b>	ACB2	7,4	11,0	130,0	D M3x9 T9F	T9F	D10	
12,7	22,0	<b>D10.0.500.22 HM</b>	AØY7	7,4	11,7	90,0	D M3x9 T9F	T9F	D10	inch
12,7	32,0	<b>D10.0.500.32 HM</b>	AB32	7,4	11,7	100,0	D M3x9 T9F	T9F	D10	inch
12,7	48,0	<b>D10.0.500.48 HM</b>	APKH	7,4	11,7	115,0	D M3x9 T9F	T9F	D10	inch
12,7	64,0	<b>D10.0.500.64 HM</b>	ADFU	7,4	11,7	130,0	D M3x9 T9F	T9F	D10	inch

Verwandte Werkzeuge finden Sie auch auf der folgenden Seite!  
Related Items can be found on the following page as well!

▶ Fortgesetzte Tabelle  
Continued Table

■ Bestellbeispiel // Order example: **D10.0012.32 HM**