

# Allgemeines Nutfräsen

Nutfräsen gerader Nutformen.  
 Geeignet ab Bohrungsdurchmesser 22,0 mm.

# General Groove Milling

General groove milling.  
 For use in bores as of minimum bore diameter 22,0 mm.

Schnittwerte (Start) // Cutting parameters (start)		
fzm	hmax	Vc
<b>0,04 mm</b>	<b>0,05 mm</b>	<b>Seite/Page 638</b>

Passende Klemmhalter auf Seite // Suitable toolholders on page  
**556, 557, 558, 559, 560, 561, 562, 563, 564**

Vergleichbare Werkzeuge auf Seite // Similar tools on page  
**461**

Bitte Hinweise im Anhang beachten // Please read add. notes  
**ALL (Seite/Page 645), H01 (Seite/Page 646)**

SP

Legende

HM

Legende

**650**

Scan QR-Code Oder besuchen Sie // Or Visit  
[www.simtek.info/cp/373](http://www.simtek.info/cp/373)

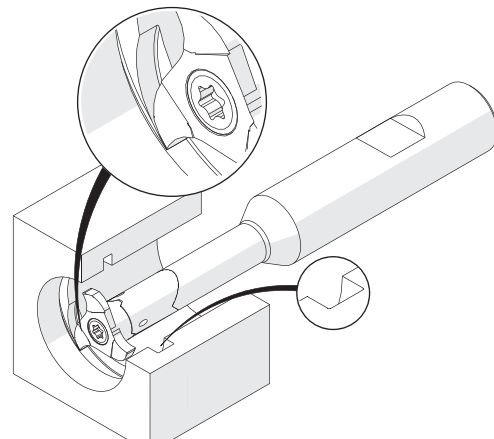
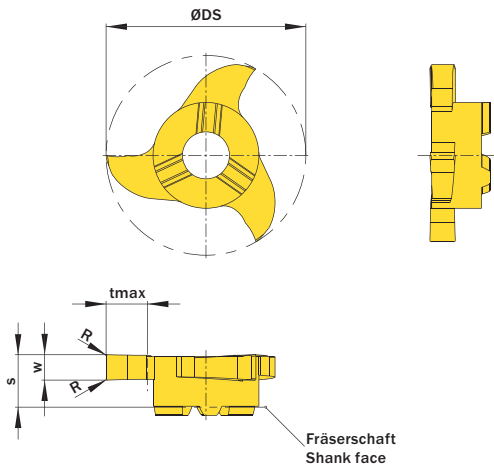

Illustration zeigt beispielhafte Anwendungsmöglichkeit mit ähnlichem Werkzeug.  
 Image shows exemplary application possibility with similar tool.

Abbildung zeigt / Drawing shows: V22.0250.02 G

w <sup>+0,02</sup>	R	ØDmin (Min. Bohrung) ØDmin (min. bore)	Artikelnummer Part number	Webcode www.simtek.com/webcode	Unsere erste Wahl Our first choice					tmax	S	ØDS	Anzahl Schneiden Number of cutting edges	Connectcode www.simtek.com/code
					P	M	K	N	S					
1,0	0,1	22,0	V22.0100.01 G	AEQM	X800	G142	4,5	5,7	21,7	3	VD12,0			
1,5	0,2	22,0	V22.0150.02 G	AHH9	X800	G142	4,5	5,7	21,7	3	VD12,0			
1,575	0,2	22,0	V22.0157.02 G	ANQX	X800	G142	4,5	5,7	21,7	3	VD12,0			
2,0	0,2	22,0	V22.0200.02 G	ADNU	X800	G142	4,5	5,7	21,7	3	VD12,0			
2,388	0,2	22,0	V22.0239.02 G	AHMN	X800	G142	4,5	5,7	21,7	3	VD12,0			
2,5	0,2	22,0	V22.0250.02 G	AKKF	X800	G142	4,5	5,7	21,7	3	VD12,0			
3,0	0,2	22,0	V22.0300.02 G	ABXX	X800	G142	4,5	5,7	21,7	3	VD12,0			
3,175	0,2	22,0	V22.0318.02 G	AK1S	X800	G142	4,5	5,7	21,7	3	VD12,0			
3,175	0,4	22,0	V22.0318.04 G	AB1P	X800	G142	4,5	5,7	21,7	3	VD12,0			
3,5	0,2	22,0	V22.0350.02 G	AM6N	X800	G142	4,5	5,7	21,7	3	VD12,0			
3,556	0,2	22,0	V22.0356.02 G	AD9Ø	X800	G142	4,5	5,7	21,7	3	VD12,0			
4,0	0,2	22,0	V22.0400.02 G	AF5N	X800	G142	4,5	5,7	21,7	3	VD12,0			
4,0	0,4	22,0	V22.0400.04 G	AGMH	X800	G142	4,5	5,7	21,7	3	VD12,0			
4,369	0,2	22,0	V22.0437.02 G	AHBP	X800	G142	4,5	5,7	21,7	3	VD12,0			
4,369	0,4	22,0	V22.0437.04 G	AEPH	X800	G142	4,5	5,7	21,7	3	VD12,0			
4,75	0,2	22,0	V22.0475.02 G	ADF7	X800	G142	4,5	5,7	21,7	3	VD12,0			
5,0	0,2	22,0	V22.0500.02 G	AZCE	X800	G142	4,5	5,7	21,7	3	VD12,0			
6,35	0,2	22,0	V22.0635.02 G	A1JU	X800	G142	4,5	9,3	21,7	3	VD12,0			

Bestellbeispiel // Order example: **V22.0300.02 G X800** (X800 = Schneidstoff // Grade)

simtek individual | V22. w, 1/100 mm, 4 Stellen/Digits | R, 1/100 mm, 3 Stellen/Digits | Toleranz // Tolerance

Beispielartikelnummer // Example Part number: **V22.0179.030 XG**