

Einstecken und Profildrehen

Geeignet ab Bohrungsdurchmesser 11,0 mm.

Grooving and Profiling

For use in bores as of minimum bore diameter 11,0 mm.

Schnittwerte (Start) // Cutting parameters (start)

| | |
|-----------|----------------|
| f | Vc |
| 0,02 mm/U | Seite/Page 429 |

Passende Klemhalter auf Seite // Suitable toolholders on page
156, 158, 161, 164

SP
HM **R**

Legende
Legend **213**

Scan
QR-Code

Oder besuchen Sie // Or Visit
www.simtek.info/cp/845



Abbildung zeigt / Drawing shows: D14.0200.02 N R

| w ^{+0,03} | R | Artikelnummer Part number | Webcode www.simtek.com/webcode | Unsere erste Wahl Our first choice | a | Ød | ØDmin (Min. Bohrung) ØDmin (min. bore) | f | s | tmax | Connectcode www.simtek.com/code |
|--------------------|----|------------------------------|-----------------------------------|---------------------------------------|----|----|---|----|----|------|------------------------------------|
| mm | mm | | | P K M N S | mm | mm | mm | mm | mm | mm | |

◀ Fortgesetzte Tabelle Continued Table Verwandte Werkzeuge finden Sie auch auf der vorhergehenden Seite! Related Items can be found on the previous page as well!

| | | | | | | | | | | | | | |
|--|------------|----------------------------|--------|--------|------|------|-------------|------------|-------------|------------|------------|------------|--------------------------------|
| ▼ ØDmin (Min. Bohrung) // ØDmin (min. bore) = 11,0 mm | | | | | | | | | | | | | |
| 1,5 | 0,2 | D10.0150.02.11 NR/L | R AC7X | L AFDW | X800 | X400 | 10,3 | 7,0 | 11,0 | 6,8 | 3,9 | 2,8 | D10 |
| 2,0 | 0,2 | D10.0200.02.11 NR/L | R AFDH | L AFVF | X800 | X400 | 10,3 | 7,0 | 11,0 | 6,8 | 3,9 | 2,8 | D10 |
| ▼ ØDmin (Min. Bohrung) // ØDmin (min. bore) = 12,0 mm | | | | | | | | | | | | | |
| 1,5 | 0,2 | D10.0150.02.12 NR/L | R AKG7 | L AHN7 | X800 | X400 | 10,9 | 7,0 | 12,0 | 7,4 | 3,9 | 3,4 | D10 |
| 2,0 | 0,2 | D10.0200.02.12 NR/L | R ANQ8 | L APHA | X800 | X400 | 10,9 | 7,0 | 12,0 | 7,4 | 3,9 | 3,4 | D10 |
| ▼ ØDmin (Min. Bohrung) // ØDmin (min. bore) = 14,0 mm | | | | | | | | | | | | | |
| 0,787 | 0,2 | D14.0078.02 NR/L | R AB9B | L AKSV | X800 | X400 | 13,5 | 9,0 | 14,0 | 9,0 | 5,3 | 4,0 | D14 |
| 1,168 | 0,2 | D14.0117.02 NR/L | R AACC | L AKHN | X800 | X400 | 13,5 | 9,0 | 14,0 | 9,0 | 5,3 | 4,0 | D14 <small>inch</small> |
| 1,5 | 0,2 | D14.0150.02 NR/L | R AAHD | L ABEJ | X800 | X400 | 13,5 | 9,0 | 14,0 | 9,0 | 5,3 | 4,0 | D14 <small>inch</small> |
| 1,575 | 0,2 | D14.0157.02 NR/L | R AMQ3 | L ABFX | X800 | X400 | 13,5 | 9,0 | 14,0 | 9,0 | 5,3 | 4,0 | D14 <small>inch</small> |
| 1,979 | 0,2 | D14.0198.02 NR/L | R APT4 | L AA5X | X800 | X400 | 13,5 | 9,0 | 14,0 | 9,0 | 5,3 | 4,0 | D14 <small>inch</small> |
| 2,0 | 0,2 | D14.0200.02 NR/L | R AC2N | L APKA | X800 | X400 | 13,5 | 9,0 | 14,0 | 9,0 | 5,3 | 4,0 | D14 |
| 2,5 | 0,2 | D14.0250.02 NR/L | R AXZA | L AXZB | X800 | X400 | 13,5 | 9,0 | 14,0 | 9,0 | 5,3 | 4,0 | D14 |
| 3,18 | 0,2 | D14.0318.02 NR/L | R AKAH | L AK9V | X800 | X400 | 13,5 | 9,0 | 14,0 | 9,0 | 5,3 | 4,0 | D14 <small>inch</small> |
| ▼ ØDmin (Min. Bohrung) // ØDmin (min. bore) = 16,0 mm | | | | | | | | | | | | | |
| 1,5 | 0,2 | D14.0150.02.16 NR/L | R AF0F | L AD21 | X800 | X400 | 15,0 | 9,0 | 16,0 | 10,5 | 5,2 | 5,5 | D14 |
| 2,0 | 0,2 | D14.0200.02.16 NR/L | R AMEQ | L ACFH | X800 | X400 | 15,0 | 9,0 | 16,0 | 10,5 | 5,2 | 5,5 | D14 |
| 2,5 | 0,2 | D14.0250.02.16 NR/L | R APQF | L AN8D | X800 | X400 | 15,0 | 9,0 | 16,0 | 10,5 | 5,2 | 5,5 | D14 |
| 3,0 | 0,2 | D14.0300.02.16 NR/L | R AD8X | L ANVS | X800 | X400 | 15,0 | 9,0 | 16,0 | 10,5 | 5,2 | 5,5 | D14 |
| ▼ ØDmin (Min. Bohrung) // ØDmin (min. bore) = 17,0 mm | | | | | | | | | | | | | |
| 2,388 | 0,2 | D14.0238.02 NR/L | R AD4A | L AM2Z | X800 | X400 | 16,0 | 9,0 | 17,0 | 11,5 | 5,5 | 6,5 | D14 <small>inch</small> |

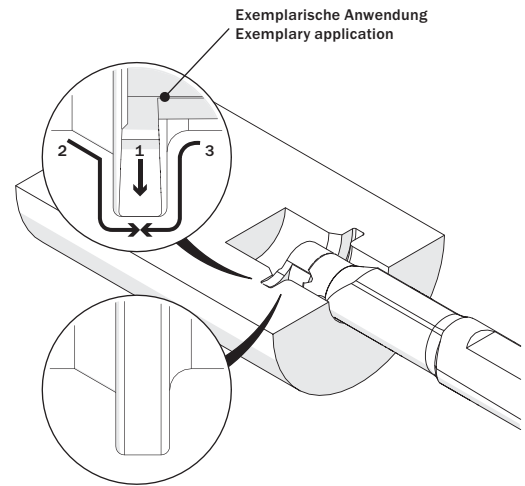
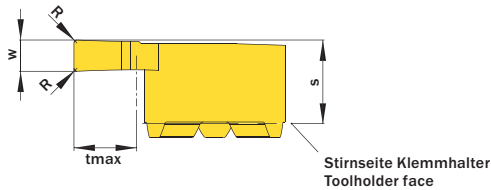
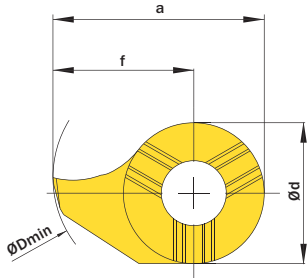
Verwandte Werkzeuge finden Sie auch auf der folgenden Seite! Related Items can be found on the following page as well!

Fortgesetzte Tabelle Continued Table ▶

Bestellbeispiel // Order example: **D14.0250.02 NR X800** (R = Rechte Ausführung // Right hand version, X800 = Schneidstoff // Grade)