

Nutenstechen

Für allgemeines Nutenstechen und für Sicherungsringnuten.
Geeignet ab Bohrungsdurchmesser 8,0 mm.

Grooving

For general grooving as well as for circlip ring grooving.
For use in bores as of minimum bore diameter 8,0 mm.

Schnittwerte (Start) // Cutting parameters (start)

f	Vc
0,02 mm/U	Seite/Page 429

Passende Klemmhalter auf Seite // Suitable toolholders on page
154, 163

Vergleichbare Werkzeuge auf Seite // Similar tools on page
175

SP

HM

R

Legende
Legend **213**

Scan
QR-Code

Oder besuchen Sie // Or Visit
www.simtek.info/cp/829



Abbildung zeigt / Drawing shows: D08.0110.00 G R

w ^{+0,03}	Nutnenbreite Nominal width of groove	ØDmin (Min. Bohrung) ØDmin (min. bore)	Artikelnummer Part number	Webcode www.simtek.com/webcode	Unsere erste Wahl Our first choice	a	Ød	f	R	S	tmax	Connectcode www.simtek.com/code
mm	mm	mm		www.simtek.com/webcode	P K M N S	mm	mm	mm	mm	mm	mm	www.simtek.com/code

Fortgesetzte Tabelle // Continued Table
Verwandte Werkzeuge finden Sie auch auf der vorhergehenden Seite!
Related items can be found on the previous page as well!

0,73	0,7	8,0	D08.0070.00 ZR/L	R AB9U L ADBZ	X800 X400	7,8	6,0	4,8	-	3,3	1,0	D08
0,787	-	8,0	D08.0078.00 GR/L	R ANEN L AH0A	X800 X400	7,8	6,0	4,8	-	3,3	1,0	D08 inch
0,83	0,8	8,0	D08.0080.00 ZR/L	R AKJ6 L AMGG	X800 X400	7,8	6,0	4,8	-	3,3	1,0	D08
0,93	0,9	8,0	D08.0090.00 ZR/L	R AN56 L AMYN	X800 X400	7,8	6,0	4,8	-	3,3	1,0	D08
1,0	-	8,0	D08.0100.00 GR/L	R AKUA L AGCE	X800 X400	7,8	6,0	4,8	-	3,3	1,0	D08
1,2	1,1	8,0	D08.0110.00 GR/L	R ABPM L ANT9	X800 X400	7,8	6,0	4,8	-	3,3	1,0	D08
1,4	1,3	8,0	D08.0130.00 GR/L	R AMN4 L AG33	X800 X400	7,8	6,0	4,8	-	3,3	1,0	D08
1,5	-	8,0	D08.0150.00 GR/L	R AK83 L AFKC	X800 X400	7,8	6,0	4,8	-	3,3	1,0	D08
1,575	-	8,0	D08.0157.00 GR/L	R AKYG L AHA1	X800 X400	7,8	6,0	4,8	-	3,3	1,0	D08 inch
1,7	1,6	8,0	D08.0160.00 GR/L	R ACV2 L AGGD	X800 X400	7,8	6,0	4,8	-	3,3	1,0	D08
1,981	-	8,0	D08.0198.00 GR/L	R AE0H L AK8B	X800 X400	7,8	6,0	4,8	-	3,3	1,0	D08 new inch
2,0	-	8,0	D08.0200.00 GR/L	R AJB6 L ANSM	X800 X400	7,8	6,0	4,8	-	3,3	1,0	D08

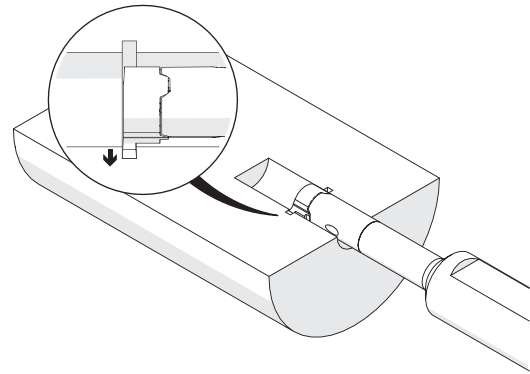
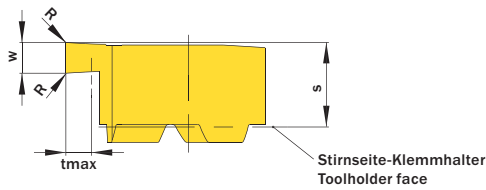
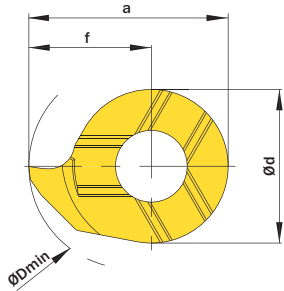
Verwandte Werkzeuge finden Sie auch auf der folgenden Seite!
Related items can be found on the following page as well!

Fortgesetzte Tabelle
Continued Table

Bestellbeispiel // Order example: **D08.0150.00 GR X800** (R = Rechte Ausführung // Right hand version, X800 = Schneidstoff // Grade)



D08. w, 1/100 mm, 4 Stellen/Digits . R, 1/100 mm, 3 Stellen/Digits Toleranz // Tolerance R/L
Beispielartikelnummer // Example Part number: **D08.0156.015 XN R** oder//or **D08.0156.015 XN L**