

# Axialstechen in Bohrungen, Vollradius

Geeignet ab Bohrungsdurchmesser 6,2 mm.

## Full Radius Face Grooving in Bores

For use in bores as of minimum bore diameter 6,2 mm.

Schnittwerte (Start) // Cutting parameters (start)

f	Vc
<b>0,02 mm/U</b>	<b>Seite/Page 429</b>

Passende Klemmhalter auf Seite // Suitable toolholders on page

**28, 31, 36, 42, 45, 50, 51, 53, 55, 56, 58, 61, 62, 64, 65, 66, 67, 68, 69**



Legende  
Legend **139**

Scan  
QR-Code

Oder besuchen Sie // Or Visit  
[www.simtek.info/cp/763](http://www.simtek.info/cp/763)



Abbildung zeigt / Drawing shows: A06.0200.15.01 AV R



Mehr Informationen zur Kühlmittelzufuhr finden Sie auf Seite 22  
Additional information about through coolant supply on page 22

ØD	w <sup>+0,05</sup>	L2	Kühlmittelzufuhr Through coolant supply	Artikelnummer Part number	Webcode <a href="http://www.simtek.com/webcode">www.simtek.com/webcode</a>	Unsere erste Wahl Our first choice	ØDmin (Min. Bohrung) ØDmin (min. bore)	f	LH	R	tmax	Connectcode <a href="http://www.simtek.com/code">www.simtek.com/code</a>
mm	mm	mm				P K M N S	mm	mm	mm	mm	mm	
6,0	1,0	15,2	+	<b>A06.0100.15.01 AV R/L</b>	R AE1C L AKM6	X800 X400	6,2	2,95	18,0	0,5	2,0	R A06.R L A06.L
6,0	1,575	15,2	+	<b>A06.0157.15.01 AV R</b>	A6MD	X800 X400	6,2	2,95	18,0	0,785	3,0	<b>A06.R</b> <small>new inch</small>
6,0	1,6	15,2	+	<b>A06.0160.15.01 AV R/L</b>	R AJPQ L AGG4	X800 X400	6,2	2,95	18,0	0,8	3,0	R A06.R L A06.L
6,0	2,0	15,2	+	<b>A06.0200.15.01 AV R/L</b>	R AB30 L AGFY	X800 X400	6,2	2,95	18,0	1,0	4,0	R A06.R L A06.L
6,0	2,39	15,2	+	<b>A06.0239.15.01 AV R</b>	A6MB	X800 X400	6,2	2,95	18,0	1,245	5,0	<b>A06.R</b> <small>new inch</small>
6,0	2,5	15,2	+	<b>A06.0250.15.01 AV R/L</b>	R AAE4 L AK4E	X800 X400	6,2	2,95	18,0	1,25	5,0	R A06.R L A06.L
6,0	3,0	15,2	+	<b>A06.0300.15.01 AV R/L</b>	R AF07 L AGBB	X800 X400	6,2	2,95	18,0	1,5	6,0	R A06.R L A06.L

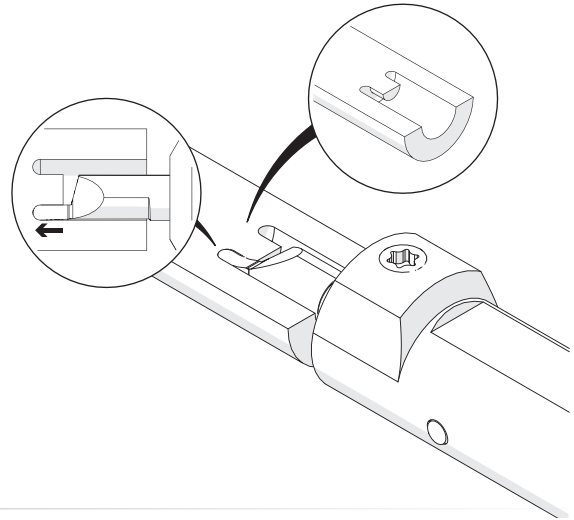
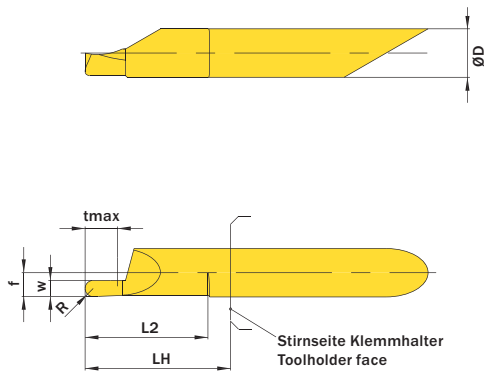
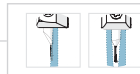
Bestellbeispiel // Order example: **A06.0100.15.01 AV R X800** (R = Rechte Ausführung // Right hand version, X800 = Schneidstoff // Grade)