

Einstecken und Profildrehen

CNC-Konturdrehen.

Grooving and Profiling

CNC profiling.

Schnittwerte (Start) // Cutting parameters (start)

| | | |
|------------------------------|------------------------------|----------------------|
| f (außen//ext.) 0,04 mm/U | f (innen//int.) 0,03 mm/U | Vc Seite/Page 429 |
|------------------------------|------------------------------|----------------------|

Passende Klemmhalter auf Seite // Suitable toolholders on page
323, 324, 325, 326, 327, 328

SP
CBN

SP
HM

R

Legende
Legend **354**

Scan
QR-Code

Oder besuchen Sie // Or Visit
www.simtek.info/cp/309

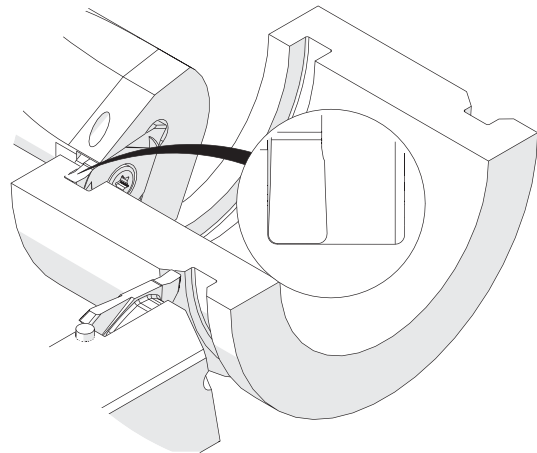
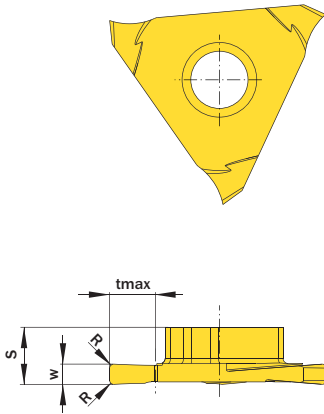

Abbildung zeigt / Drawing shows: TE3.0200.04 NR

| w ±0,02 mm | R mm | Artikelnummer Part number | Webcode www.simtek.com/webcode | Unsere erste Wahl Our first choice | S mm | tmax mm | Connectcode www.simtek.com/code | |
|----------------------|---------|------------------------------|-----------------------------------|---------------------------------------|---------|------------|------------------------------------|--|
| ▼ R = 0,05 mm | | | | | | | | |
| 1,0 | 0,05 | TE3.0100.005 N R/L | R A1T4 L A41Z | X808 X408 | 5,45 | 2,5 | R TE3.R.5.3 L TE3.L.5.3 new | |
| ▼ R = 0,2 mm | | | | | | | | |
| 1,0 | 0,2 | TE3.0100.02 N R/L | R AUKW L AUKX | X808 X408 | 5,45 | 2,5 | R TE3.R.5.3 L TE3.L.5.3 | |
| 1,5 | 0,2 | TE3.0150.02 N R/L | R AGUC L AJCØ | X800 X400 | 5,6 | 5,0 | R TE3.R.5.3 L TE3.L.5.3 | |
| 2,0 | 0,2 | TE3.0200.02 N R/L | R AAFU L AMG1 | X800 X400 | 5,6 | 5,0 | R TE3.R.5.3 L TE3.L.5.3 | |
| 2,388 | 0,2 | TE3.0238.02 N R | A55T | X800 X400 | 5,6 | 5,0 | TE3.R.5.3 new | |
| 2,5 | 0,2 | TE3.0250.02 N R/L | R AQHV L AQHW | X800 X400 | 5,55 | 5,0 | R TE3.R.5.3 L TE3.L.5.3 | |
| 3,0 | 0,2 | TE3.0300.02 N R/L | R AEY1 L AJYY | X800 X400 | 5,55 | 5,0 | R TE3.R.5.3 L TE3.L.5.3 | |
| 3,175 | 0,2 | TE3.0318.02 N R | A55V | X800 X400 | 5,6 | 5,0 | TE3.R.5.3 new | |
| 4,0 | 0,2 | TE3.0400.02 N R/L | R ABXC L AB96 | X800 X400 | 5,6 | 5,0 | R TE3.R.5.3 L TE3.L.5.3 | |
| 4,75 | 0,2 | TE3.0475.02 N R | A55X | X800 X400 | 5,6 | 5,0 | TE3.R.5.3 new | |
| ▼ R = 0,4 mm | | | | | | | | |
| 2,0 | 0,4 | TE3.0200.04 N R/L | R AQMV L AQMW | X800 X400 | 5,6 | 5,0 | R TE3.R.5.3 L TE3.L.5.3 | |
| 2,5 | 0,4 | TE3.0250.04 N R/L | R AG8Y L AGBH | X800 X400 | 5,6 | 5,0 | R TE3.R.5.3 L TE3.L.5.3 | |
| 3,0 | 0,4 | TE3.0300.04 N R/L | R AQHY L AQHX | X800 X400 | 5,6 | 5,0 | R TE3.R.5.3 L TE3.L.5.3 | |
| 4,0 | 0,4 | TE3.0400.04 N R/L | R ASE2 L ASE1 | X800 X400 | 5,6 | 5,0 | R TE3.R.5.3 L TE3.L.5.3 | |
| ▼ R = 0,6 mm | | | | | | | | |
| 3,0 | 0,6 | TE3.0300.06 N R/L | R AT61 L AT60 | X800 X400 | 5,6 | 5,0 | R TE3.R.5.3 L TE3.L.5.3 | |
| ▼ R = 0,8 mm | | | | | | | | |
| 3,0 | 0,8 | TE3.0300.08 N R/L | R AT7T L AT7S | X800 X400 | 5,6 | 5,0 | R TE3.R.5.3 L TE3.L.5.3 | |

Bestellbeispiel // Order example: **TE3.0200.02 N R X800** (R = Rechte Ausführung // Right hand version, X800 = Schneidstoff // Grade)

simtek individual | TE3. w, 1/100 mm, 4 Stellen/Digits | R, 1/100 mm, 3 Stellen/Digits | Toleranz // Tolerance R/L
 Beispielartikelnummer // Example Part number: **TE3.0156.015 XN R** oder/ or **TE3.0156.015 XN L**