

## Einstecken und Profildrehen, Vollradius

Vollradiusnuten, CNC-Konturdrehen.

## Grooving and Profiling, Full Radius

Full radius, CNC profiling.

Schnittwerte (Start) // Cutting parameters (start)

f (außen//ext.) <b>0,04 mm/U</b>	f (innen//int.) <b>0,03 mm/U</b>	Vc <b>Seite/Page 429</b>
-------------------------------------	-------------------------------------	-----------------------------

Passende Klemmhalter auf Seite // Suitable toolholders on page  
**323, 324, 325, 326, 327, 328**



**SP** **HM** **R** Legende Legend **354**

Scan QR-Code Oder besuchen Sie // Or Visit [www.simtek.info/cp/310](http://www.simtek.info/cp/310)

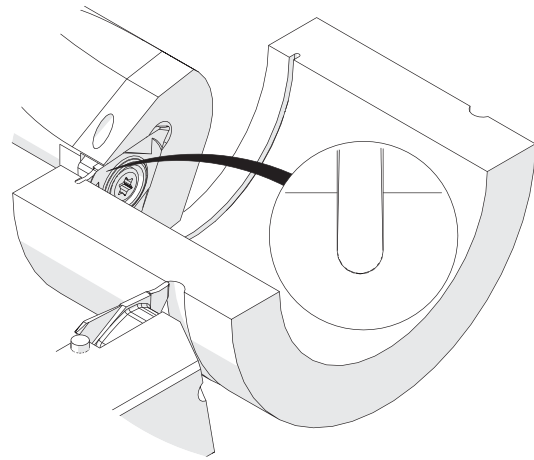
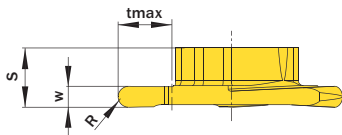
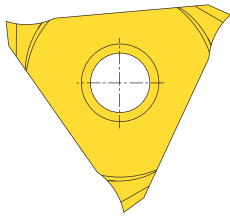

Abbildung zeigt / Drawing shows: TE3.0200.10 VR

w <sup>+0,04</sup> mm	R mm	Artikelnummer Part number	Webcode www.simtek.com/webcode	Unsere erste Wahl Our first choice		S mm	tmax mm	Connectcode www.simtek.com/code			
				P	K			M	N	S	R
1,0	0,5	<b>TE3.0100.05 VR/L</b>	R AA7W L ANCX	X800	X400	5,45	2,5	R	TE3.R.5.3	L	TE3.L.5.3
1,2	0,6	<b>TE3.0120.06 VR/L</b>	R AHPN L AK8F	X800	X400	5,6	3,0	R	TE3.R.5.3	L	TE3.L.5.3
1,5	0,75	<b>TE3.0150.07 VR/L</b>	R AT74 L AT73	X800	X400	5,6	5,0	R	TE3.R.5.3	L	TE3.L.5.3
1,575	0,79	<b>TE3.0157.079 VR</b>	A449	X800	X400	5,6	5,0		<b>TE3.R.5.3</b>		
<b>1,6</b>	<b>0,8</b>	<b>TE3.0160.08 VR/L</b>	R <b>AB6N</b> L <b>AJAC</b>	X800	X400	5,6	<b>5,0</b>	R	<b>TE3.R.5.3</b>	L	<b>TE3.L.5.3</b>
1,8	0,9	<b>TE3.0180.09 VR/L</b>	R AFP3 L AKC9	X800	X400	5,6	5,0	R	TE3.R.5.3	L	TE3.L.5.3
2,0	1,0	<b>TE3.0200.10 VR/L</b>	R APHH L ACYV	X800	X400	5,6	5,0	R	TE3.R.5.3	L	TE3.L.5.3
2,2	1,1	<b>TE3.0220.11 VR/L</b>	R AJ0Q L ANTV	X800	X400	5,6	5,0	R	TE3.R.5.3	L	TE3.L.5.3
2,5	1,25	<b>TE3.0250.12 VR/L</b>	R AAFE L AMTK	X800	X400	5,6	5,0	R	TE3.R.5.3	L	TE3.L.5.3
2,8	1,4	<b>TE3.0280.14 VR/L</b>	R ANA5 L AMFA	X800	X400	5,6	5,0	R	TE3.R.5.3	L	TE3.L.5.3
3,0	1,5	<b>TE3.0300.15 VR/L</b>	R AB7P L AD5J	X800	X400	5,6	5,0	R	TE3.R.5.3	L	TE3.L.5.3
3,6	1,8	<b>TE3.0360.18 VR/L</b>	R AT00 L AT01	X800	X400	5,6	5,0	R	TE3.R.5.3	L	TE3.L.5.3
4,0	2,0	<b>TE3.0400.20 VR/L</b>	R ANK8 L APDZ	X800	X400	5,6	5,0	R	TE3.R.5.3	L	TE3.L.5.3

Bestellbeispiel // Order example: **TE3.0160.08 V R X800** (R = Rechte Ausführung // Right hand version, X800 = Schneidstoff // Grade)

new  
 item