

# Klemmhalter, Innenbearbeitung, Rundschaft

Rundschaft mit innerer Kühlmittelzufuhr für die Größe A04.

## Toolholder, Internal Applications, Round Shank

Round shank with through coolant for size A04.

Anzugsmoment (Schraube) // Tightening torque (screw)

**7,0 Nm**

Bitte Hinweise im Anhang beachten // Please read add. notes

**MASTER (Seite/Page 137)**



Legende  
Legend

**139**



Scan  
QR-Code

Oder besuchen Sie // Or Visit  
[www.simtek.info/cp/746](http://www.simtek.info/cp/746)

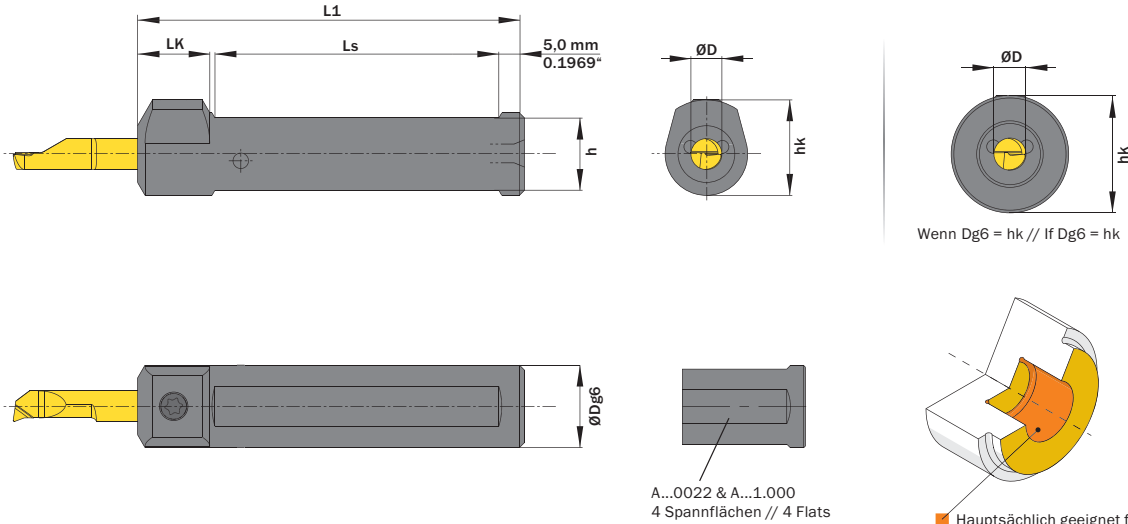

ØD	ØDg6	Artikelnummer Part number	Webcode www.simtek.com/webcode	h	hk	L1	LK	Ls	Anzahl Spannflächen Number of flats	Schraube Screw	Schraubenschlüssel Screw driver	Connectcode www.simtek.com/code
4,0	10,0	<b>A04.0010</b>	AE46	8,0	14,5	65,0	14,0	45,0	2	AM6x7,5 T15F	T15F	A04.L A04.R
4,0	12,0	<b>A04.0012</b>	AE0X	10,0	15,5	70,0	14,0	50,0	2	AM6x7,5 T15F	T15F	A04.L A04.R
4,0	12,7	<b>A04.0.500</b>	AB2J	10,7	15,8	70,0	14,0	50,0	2	AM6x7,5 T15F	T15F	A04.L A04.R
4,0	15,875	<b>A04.0.625</b>	ACVJ	13,9	17,4	75,0	14,0	55,0	2	AM6x7,5 T15F	T15F	A04.L A04.R
4,0	16,0	<b>A04.0016</b>	AF2K	14,0	17,5	75,0	14,0	55,0	2	AM6x7,5 T15F	T15F	A04.L A04.R
4,0	19,05	<b>A04.0.750</b>	AJ4A	17,0	19,0	110,0	14,0	90,0	2	AM6x7,5 T15F	T15F	A04.L A04.R
4,0	20,0	<b>A04.0020</b>	AC6Y	18,0	20,0	90,0	14,0	70,0	2	AM6x7,5 T15F	T15F	A04.L A04.R
4,0	22,0	<b>A04.0022</b>	AD0V	20,0	22,0	110,0	-	90,0	4	AM6x7,5 T15F	T15F	A04.L A04.R
4,0	23,0	<b>A04.0023</b>	ANU4	21,0	23,0	110,0	-	90,0	2	AM6x7,5 T15F	T15F	A04.L A04.R
4,0	25,0	<b>A04.0025</b>	ACAS	23,0	25,0	110,0	-	90,0	2	AM6x7,5 T15F	T15F	A04.L A04.R
4,0	25,4	<b>A04.1.000</b>	AJWG	23,4	25,4	110,0	-	90,0	4	AM6x7,5 T15F	T15F	A04.L A04.R

Verwandte Werkzeuge finden Sie auch auf der folgenden Seite!  
Related items can be found on the following page as well!

Fortgesetzte Tabelle  
Continued Table

Bestellbeispiel // Order example: **A04.0016**