

Gewindedrehen, ACME / STUB-ACME, Teilprofil

Teilprofil für ACME- und STUB-ACME-Gewinde.

Threading, ACME / STUB-ACME, Partial Profile

Partial profile for internal ACME- and STUB-ACME thread.

Schnittwerte (Start) // Cutting parameters (start)

Anzahl Durchgänge // Number of passes **12 - 18**

Empf. Zustellungsart // Recom. infeed method
Modifizierte einseitige Flankenzustellung // Modified one-sided flank infeed (Seite/Page 447)

Vc
Seite/Page 442

Passende Klemmhalter auf Seite // Suitable toolholders on page
172, 173, 178, 180, 181



Legende
Legend **238**

Scan QR-Code Oder besuchen Sie // Or Visit
www.simtek.info/cp/820

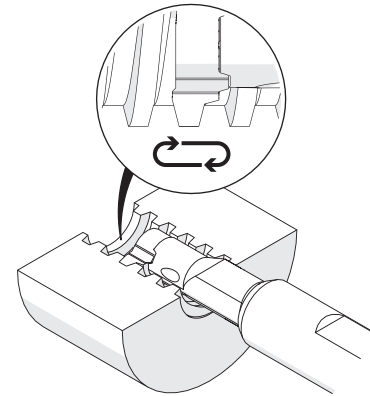
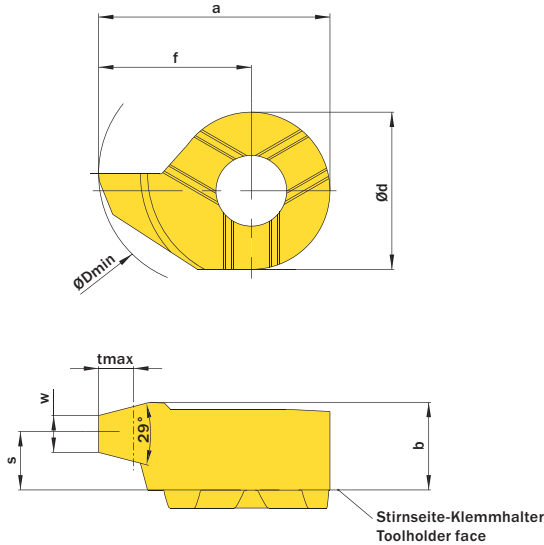

Gang/Zoll Threads/Inch	ØDmin (Min. Bohrung) ØDmin (mm. bore)	Gewindetyp	Artikelnummer Part number	Webcode www.simtek.com/webcode	Empfohlene Schneidstoffe Tagesaktuelle Verfügbarkeit und Preise finden Sie auf www.simtek.com/webcode Recommended cutting grades You can find current availability and prices on www.simtek.com/webcode	a	b	Ød	f	Steigung (von) Pitch (as of)	S	w	tmax	Connectcode www.simtek.com/ccode
▼ Gang/Zoll // Threads/Inch = 10														
10	10,0	STUB-ACME	D10.SA10.01.10 MR/L	R AGDD L AFWG	X800 X400 X600 GX79 X500 X400	9,3	3,9	7,0	5,8	2,54	2,9	0,94	1,19	D10
▼ Gang/Zoll // Threads/Inch = 12														
12	10,0	STUB-ACME	D10.SA12.01.10 MR/L	R AS1G L ATV7	X800 X400 X600 GX79 X500 X400	9,3	3,9	7,0	5,8	2,117	2,95	0,82	0,92	D10
▼ Gang/Zoll // Threads/Inch = 5														
5	11,0	ACME	D10.AC05.01.11 MR/L	R A3TD L BC0J	X800 X400 X600 GX79 X500 X400	10,3	3,7	7,0	6,8	5,08	1,9	1,75	2,79	D10 new
5	10,0	STUB-ACME	D10.SA05.01.10 MR/L	R AFAM L AE4B	X800 X400 X600 GX79 X500 X400	9,3	3,7	7,0	5,8	5,08	1,95	2,01	2,04	D10
▼ Gang/Zoll // Threads/Inch = 6														
6	11,0	ACME	D10.AC06.01.11 MR/L	R AEAB L AJ18	X800 X400 X600 GX79 X500 X400	10,3	3,9	7,0	6,8	4,233	2,3	1,43	2,63	D10
6	10,0	STUB-ACME	D10.SA06.01.10 MR/L	R AK49 L AGC9	X800 X400 X600 GX79 X500 X400	9,3	3,7	7,0	5,8	4,233	2,35	1,65	1,76	D10
6	11,0	ACME	D11.AC06.01 MR/L	R AKTH L ATV6	X800 X400 X600 GX79 X500 X400	10,7	3,95	8,0	6,7	4,233	2,5	1,43	2,39	D11
▼ Gang/Zoll // Threads/Inch = 8														
8	11,0	ACME	D10.AC08.01.11 MR/L	R AJCF L AHZU	X800 X400 X600 GX79 X500 X400	10,3	3,9	7,0	6,8	3,175	2,65	1,04	2,1	D10
8	10,0	STUB-ACME	D10.SA08.01.10 MR/L	R AB7E L AF6Z	X800 X400 X600 GX79 X500 X400	9,3	3,72	7,0	5,8	3,175	2,3	1,21	1,41	D10

Bestellbeispiel // Order example: **D10.SA06.01.10 MR X800** (R = Rechte Ausführung // Right hand version, X800 = Schneidstoff // Grade)