

Fräsen von Fasen

Fasenfräsen beidseitig. Geeignet ab Bohrungsdurchmesser 6,0 mm. Aufnahme nach DIN 6535 HA.

Chamfering

Chamfering on both sides. For use in bores as of minimum bore diameter 6,0 mm. Shank according to DIN 6535 HA.

Schnittwerte (Start) // Cutting parameters (Start)

f _{zm} 0,02 mm	h _{max} 0,03 mm	V _c Seite/Page 638
-----------------------------------	------------------------------------	---

Bitte Hinweise im Anhang beachten // Please read add. notes

ALL (Seite/Page 645)



SP Legende
HM Legend
650

Scan QR-Code Oder besuchen Sie // Or Visit
www.simtek.info/cp/293

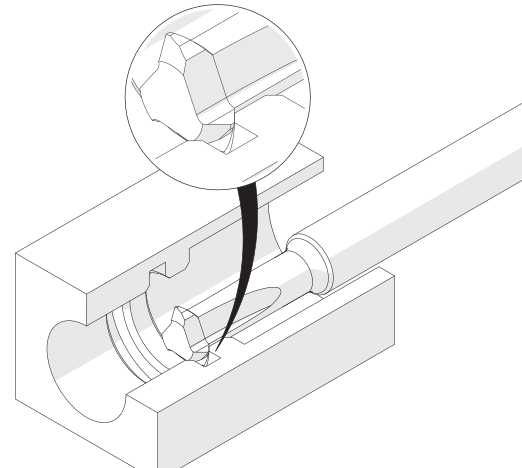
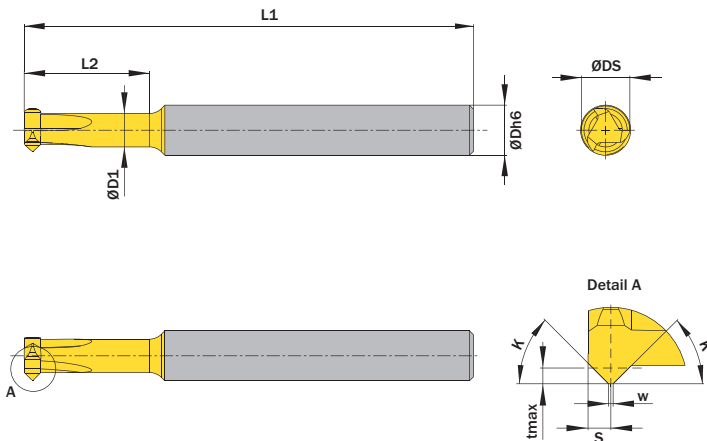

Illustration zeigt beispielhafte Anwendungsmöglichkeit mit ähnlichem Werkzeug.
Image shows exemplary application possibility with similar tool.

Abbildung zeigt / Drawing shows: MA3.4545.02.15.06 AF

K	w	L2	ØDmin (Min. Bohrung) ØDmin (min. bore)	Artikelnummer Part number	Webcode www.simtek.com/webcode	Unsere erste Wahl Our first choice		Anzahl Schneiden Number of cutting edges	ØD1	ØDh6	ØDS	L1	S	tmax	Connectcode www.simtek.com/code
						B	S								
▼ ØDmin (Min. Bohrung) // ØDmin (min. bore) = 6,0 mm															
45°	0,2	15,0	6,0	MA3.4545.02.15.06 AF	AHTP	X800	GT42	3	4,2	6,0	5,8	58,0	1,0	0,6	-
45°	0,2	15,0	6,0	MA3.4545.02.15.250 AF	AS4Q	X800	GT42	3	4,2	6,35	5,8	58,0	1,0	0,6	-
45°	0,2	25,0	6,0	MA3.4545.02.25.06 AF	AC3U	X800	GT42	3	4,2	6,0	5,8	68,0	1,0	0,6	-
45°	0,2	25,0	6,0	MA3.4545.02.25.250 AF	AS4H	X800	GT42	3	4,2	6,35	5,8	68,0	1,0	0,6	-
▼ ØDmin (Min. Bohrung) // ØDmin (min. bore) = 8,0 mm															
45°	0,2	25,0	8,0	MA3.4545.02.25.08 AF	AKDE	X800	GT42	3	5,0	8,0	7,8	68,0	1,5	1,2	-
45°	0,2	25,0	8,0	MA3.4545.02.25.312 AF	AS4J	X800	GT42	3	5,0	7,92	7,8	68,0	1,5	1,2	-
45°	0,2	35,0	8,0	MA3.4545.02.35.08 AF	AKCW	X800	GT42	3	5,0	8,0	7,8	78,0	1,5	1,2	-
45°	0,2	35,0	8,0	MA3.4545.02.35.312 AF	AS4N	X800	GT42	3	5,0	7,92	7,8	78,0	1,5	1,2	-

Bestellbeispiel // Order example: **MA3.4545.02.15.06 AF X800** (X800 = Schneidstoff // Grade)