

Stechen von Vollradiusnuten

Geeignet ab Bohrungsdurchmesser 4,2 mm.

Full Radius Grooving

For use in bores as of minimum bore diameter 4,2 mm.

Schnittwerte (Start) // Cutting parameters (start)

f	Vc
0,02 mm/U	Seite/Page 429

Passende Klemmhalter auf Seite // Suitable toolholders on page

27, 28, 31, 32, 33, 34, 35, 36, 40,
41, 42, 43, 44, 45, 50, 51, 53, 55,
56, 57, 58, 60, 61, 62, 63, 64, 65,
66, 67, 68, 69



SP **HM** **R** Legende Legend 139

Scan QR-Code Oder besuchen Sie // Or Visit www.simtek.info/cp/778



Abbildung zeigt / Drawing shows: A06.0150.25.62 VR

Mehr Informationen zur Kühlmittelzufuhr finden Sie auf Seite 22
Additional information about through coolant supply on page 22

ØD	w ^{+0,03}	L2	ØDmin (Min. Bohrung) ØDmin (min. bore)	Kühlmittelzufuhr Through coolant supply	Artikelnummer Part number	Webcode www.simtek.com/webcode	Unsere erste Wahl Our first choice	a	d	f	LH	R	tmax	Connectcode www.simtek.com/code
mm	mm	mm	mm				P K M N S	mm	mm	mm	mm	mm	mm	
▼ ØD = 4,0 mm														
4,0	1,0	15,2	4,2	+	A04.0100.15.42 VR/L	R AC9G L ACXS	X800 X400	3,95	2,95	1,95	18,0	0,5	0,8	R A04C.R L A04C.L
4,0	1,168	15,2	4,2	+	A04.0117.15.42 VR/L	R AG4M L AGZT	X800 X400	3,95	2,95	1,95	18,0	0,58	0,8	R A04C.R L A04C.L inch
▼ ØD = 5,0 mm														
5,0	1,0	20,3	5,2	+	A05.0100.20.52 VR/L	R AHPY L AMKU	X800 X400	4,95	3,75	2,45	23,0	0,5	1,0	R A05.R L A05.L
5,0	1,168	20,3	5,2	+	A05.0117.20.52 VR/L	R AGGW L AFDM	X800 X400	4,95	3,75	2,45	23,0	0,58	1,0	R A05.R L A05.L inch
5,0	1,5	20,3	5,2	+	A05.0150.20.52 VR/L	R AA2S L ACC3	X800 X400	4,95	3,75	2,45	23,0	0,75	1,0	R A05.R L A05.L
5,0	1,575	20,3	5,2	+	A05.0157.20.52 VR/L	R AM8X L APCC	X800 X400	4,95	3,75	2,45	23,0	0,79	1,0	R A05.R L A05.L inch
5,0	1,626	20,3	5,2	+	A05.0163.20.52 VR/L	R AT8E L AT8D	X800 X400	4,95	3,75	2,45	23,0	0,81	1,0	R A05.R L A05.L inch
5,0	1,981	20,3	5,2	+	A05.0198.20.52 VR/L	R AT8G L AT8F	X800 X400	4,95	3,75	2,45	23,0	0,99	1,0	R A05.R L A05.L inch
5,0	2,0	20,3	5,2	+	A05.0200.20.52 VR/L	R AK1U L AMG6	X800 X400	4,95	3,75	2,45	23,0	1,0	1,0	R A05.R L A05.L
▼ ØD = 6,0 mm														
6,0	1,0	25,4	6,2	+	A06.0100.25.62 VR/L	R AKUZ L AFNY	X800 X400	5,95	3,95	2,95	28,0	0,5	1,8	R A06.R L A06.L
6,0	1,168	25,4	6,2	+	A06.0117.25.62 VR/L	R AKMZ L AGQY	X800 X400	5,95	3,95	2,95	28,0	0,58	1,8	R A06.R L A06.L inch
6,0	1,5	25,4	6,2	+	A06.0150.25.62 VR/L	R AD22 L AMMJ	X800 X400	5,95	3,95	2,95	28,0	0,75	1,8	R A06.R L A06.L
6,0	1,575	25,4	6,2	+	A06.0157.25.62 VR/L	R APSG L ANCZ	X800 X400	5,95	3,95	2,95	28,0	0,79	1,8	R A06.R L A06.L inch
6,0	1,626	25,4	6,2	+	A06.0163.25.62 VR/L	R AT8J L AT8H	X800 X400	5,95	3,95	2,95	28,0	0,81	1,8	R A06.R L A06.L inch
6,0	1,981	25,4	6,2	+	A06.0198.25.62 VR/L	R AT8M L AT8K	X800 X400	5,95	3,95	2,95	28,0	0,99	1,8	R A06.R L A06.L inch
6,0	2,0	20,3	6,2	+	A06.0200.20.62 VR/L	R AMVK L AFV9	X800 X400	5,95	3,95	2,95	23,0	1,0	1,8	R A06.R L A06.L
6,0	2,0	25,4	6,2	+	A06.0200.25.62 VR/L	R AH3S L AKZ8	X800 X400	5,95	3,95	2,95	28,0	1,0	1,8	R A06.R L A06.L

Verwandte Werkzeuge finden Sie auch auf der folgenden Seite!
Related Items can be found on the following page as well!

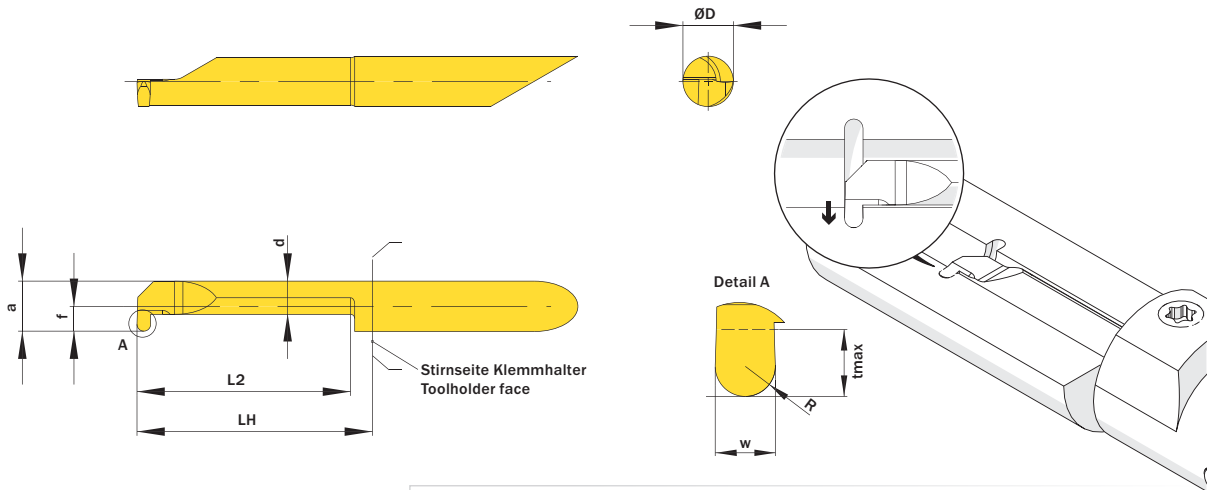
Fortgesetzte Tabelle
Continued Table ▶

Bestellbeispiel // Order example: **A06.0200.25.62 VR X800** (R = Rechte Ausführung // Right hand version, X800 = Schneidstoff // Grade)