

Allgemeines Nutfräsen

Nutfräsen gerader Nutformen.
Geeignet ab Bohrungsdurchmesser 14,0 mm.

General Groove Milling

General groove milling.
For use in bores as of minimum bore diameter 14,0 mm.

Schnittwerte (Start) // Cutting parameters (start)		
fzm 0,02 mm	hmax 0,03 mm	Vc Seite/Page 638
Passende Klemmhalter auf Seite // Suitable toolholders on page		
508, 509, 510, 511, 512		
Vergleichbare Werkzeuge auf Seite // Similar tools on page		
461		
Bitte Hinweise im Anhang beachten // Please read add. notes		
ALL (Seite/Page 645), H01 (Seite/Page 646)		

SP

Legende

HM

Legend

Scan QR-Code

650

Oder besuchen Sie // Or Visit
www.simtek.info/cp/359

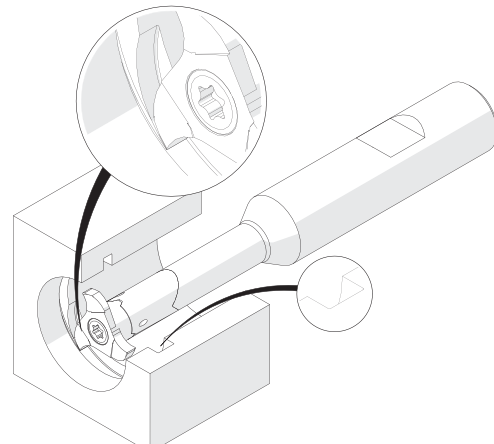
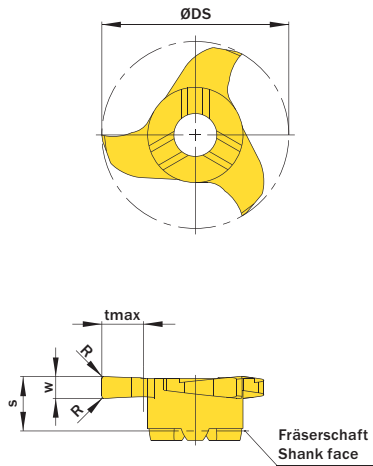

Illustration zeigt beispielhafte Anwendungsmöglichkeit mit ähnlichem Werkzeug.
Image shows exemplary application possibility with similar tool.

Abbildung zeigt / Drawing shows: S16.0200.02 G

w ^{+0,02} mm	Nutnenbreite Nominal width of groove mm	R mm	ØDmin (Min. Bohrung) ØDmin (min. bore) mm	Artikelnummer Part number	Webcode www.simtek.com/webcode	Unsere erste Wahl Our first choice		tmax mm	S mm	ØDS mm	Anzahl Schneiden Number of cutting edges	Connectcode www.simtek.com/code
						P M K N S						
1,04	-	-	14,0	S14.0100.00 G	AVH6	X800	GT42	2,5	4,5	13,7	3	SD08.0
1,0	-	0,1	14,0	S14.0100.01 G	ADNZ	X800	GT42	2,5	4,5	13,7	3	SD08.0
1,168	-	-	14,0	S14.0117.00 G	AB4V	X800	GT42	2,5	4,5	13,7	3	SD08.0 inch
1,422	-	-	14,0	S14.0142.00 G	AAD1	X800	GT42	2,5	4,5	13,7	3	SD08.0 inch
1,5	-	0,2	14,0	S14.0150.02 G	AGJ3	X800	GT42	2,5	4,5	13,7	3	SD08.0
1,575	-	0,2	14,0	S14.0157.02 G	AHP3	X800	GT42	2,5	4,5	13,7	3	SD08.0 inch
2,0	-	0,2	14,0	S14.0200.02 G	AMG7	X800	GT42	2,5	4,5	13,7	3	SD08.0
2,388	-	0,2	14,0	S14.0239.02 G	APC6	X800	GT42	2,5	4,5	13,7	3	SD08.0 inch
2,5	-	0,2	14,0	S14.0250.02 G	ANZT	X800	GT42	2,5	4,5	13,7	3	SD08.0

Bestellbeispiel // Order example: **S14.0250.02 G X800** (X800 = Schneidstoff // Grade)



S14. w, 1/100 mm, 4 Stellen/Digits . R, 1/100 mm, 3 Stellen/Digits Toleranz // Tolerance
Beispielartikelnummer // Example Part number: **S14.0179.030 XG**