

Eckenfreistiche, Vollradius

Eckenfreistiche, Vollradius mit hohen seitlichen Freiwinkeln.

Corner Relief, Full Radius

Corner relief, full radius with increased lateral relief angles.

Schnittwerte (Start) // Cutting parameters (start)

f	Vc
0,04 mm/U	Seite/Page 429

Passende Klemmhalter auf Seite // Suitable toolholders on page

361, 362, 363, 364, 365, 367, 368



SP Legende
HM Legend

389

Scan QR-Code

Oder besuchen Sie // Or Visit
www.simtek.info/cp/508

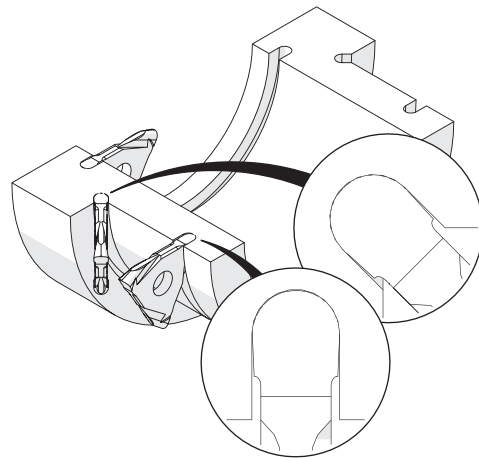
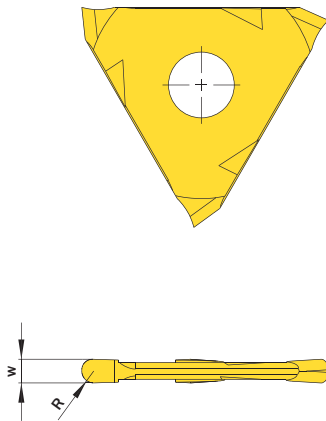

Abbildung zeigt / Drawing shows: E12.0010.20 V

R	w $\pm 0,03$	Artikelnummer Part number	Webcode www.simtek.com/webcode	Unsere erste Wahl Our first choice	Connectcode www.simtek.com/code
mm	mm			P K M N S	
1,0	2,0	E12.0010.20 V	AGXF	X800 X400	E12.A1 E12.A2
1,2	2,4	E12.0012.24 V	AM15	X800 X400	E12.A2 E12.B2
1,5	3,0	E12.0015.30 V	APVW	X800 X400	E12.B2
2,0	4,0	E12.0020.40 V	ANJ2	X800 X400	E12.C3
2,5	5,0	E12.0025.50 V	AHJ2	X800 X400	E12.D4
3,0	6,0	E12.0030.60 V	AJ0T	X800 X400	E12.D4

Bestellbeispiel // Order example: **E12.0012.24 V X800** (X800 = Schneidstoff // Grade)