

Ausdrehen, Hartbearbeitung und WIPER-Geometrie

In Verbindung mit einem CBN-Schneidstoff besonders geeignet für die Hartbearbeitung ab Bohrungsdurchmesser 6,2 mm.

Boring, Hard Part Turning plus WIPER-Geometry

First choice for hard part turning applications in bores as of bore diameter 6,2 mm in combination with our CBN grades.

Schnittwerte (Start) // Cutting parameters (start)	
f 0,02 mm/U	Vc Seite/Page 429
Passende Klemmhalter auf Seite // Suitable toolholders on page 27, 28, 29, 31, 33, 35, 36, 37, 41, 42, 44, 45, 46, 50, 51, 52, 53, 54, 55, 56, 57, 58, 61, 62, 63, 64, 65, 66, 67, 68, 69	
Vergleichbare Werkzeuge auf Seite // Similar tools on page 88	

SP
CBN **R**

Scan QR-Code

Legende Legend **139**

Oder besuchen Sie // Or visit www.simtek.info/cp/1063

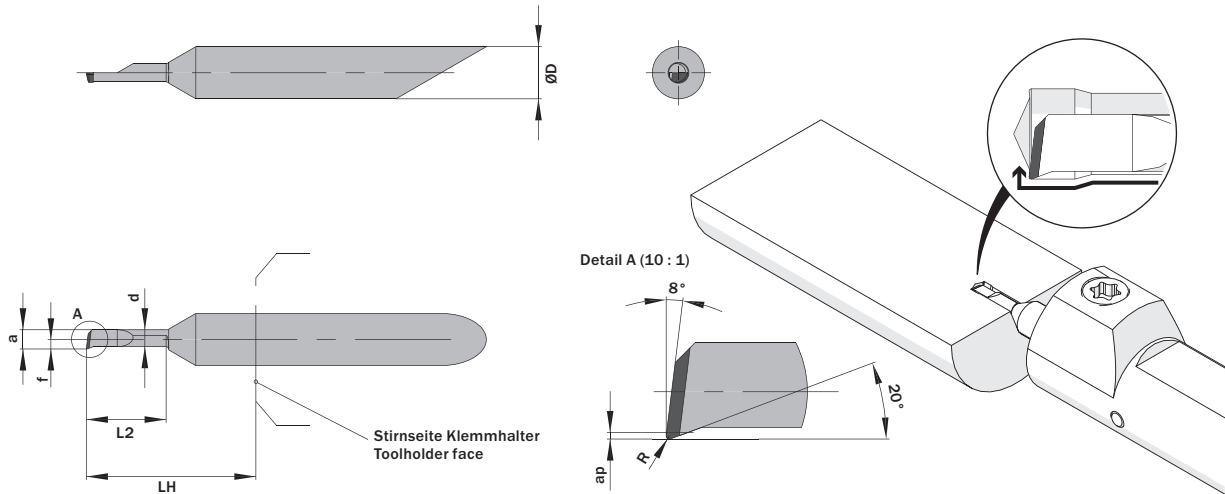

Mehr Informationen zur Kühlmittelzufuhr finden Sie auf Seite 22
Additional information about through coolant supply on page 22

ØD	L2	ØDmin (Min. Bohrung) ØDmin (min. bore)	R	Kühlmittelzufuhr Through coolant supply	Artikelnummer Part number	Webcode www.simtek.com/webcode	Unsere erste Wahl Our first choice	a	ap	d	f	LH	Connectcode www.simtek.com/code
mm	mm	mm	mm				H	mm	mm	mm	mm	mm	

Fortgesetzte Tabelle Continued Table **Verwandte Werkzeuge finden Sie auch auf der vorhergehenden Seite!**
Related items can be found on the previous page as well!

▼ ØDmin (Min. Bohrung) // ØDmin (min. bore) = 5,2 mm

5,0	10,2	5,2	0,2	+	A05.1825.10.52.20 YUR/L	R AHH5 L AHHM	CBN	4,95	0,26	4,25	2,45	13,0	R A05.R L A05.L
5,0	15,2	5,2	0,2	+	A05.1825.15.52.20 YUR/L	R AD1K L AE8S	CBN	4,95	0,26	4,25	2,45	18,0	R A05.R L A05.L
5,0	20,3	5,2	0,2	+	A05.1825.20.52.20 YUR/L	R AHAX L AM28	CBN	4,95	0,26	4,25	2,45	23,0	R A05.R L A05.L
5,0	25,4	5,2	0,2	+	A05.1825.25.52.20 YUR/L	R AA87 L ADPG	CBN	4,95	0,26	4,25	2,45	28,0	R A05.R L A05.L
5,0	30,5	5,2	0,2	+	A05.1825.30.52.20 YUR/L	R ADNS L ABNV	CBN	4,95	0,26	4,25	2,45	33,0	R A05.R L A05.L
5,0	40,6	5,2	0,2	+	A05.1825.40.52.20 YUR/L	R AJBN L AF1T	CBN	4,95	0,26	4,25	2,45	43,0	R A05.R L A05.L

▼ ØDmin (Min. Bohrung) // ØDmin (min. bore) = 6,2 mm

6,0	15,2	6,2	0,2	+	A06.1830.15.62.20 YUR/L	R ADEW L APKD	CBN	5,95	0,31	5,25	2,95	18,0	R A06.R L A06.L
6,0	20,3	6,2	0,2	+	A06.1830.20.62.20 YUR/L	R AEWG L AD88	CBN	5,95	0,31	5,25	2,95	23,0	R A06.R L A06.L
6,0	25,4	6,2	0,2	+	A06.1830.25.62.20 YUR/L	R ACXE L AH4U	CBN	5,95	0,31	5,25	2,95	28,0	R A06.R L A06.L
6,0	30,5	6,2	0,2	+	A06.1830.30.62.20 YUR/L	R AEJ9 L AGTA	CBN	5,95	0,31	5,25	2,95	33,0	R A06.R L A06.L
6,0	35,6	6,2	0,2	+	A06.1830.35.62.20 YUR/L	R ANYT L ANN5	CBN	5,95	0,31	5,25	2,95	38,0	R A06.R L A06.L
6,0	40,6	6,2	0,2	+	A06.1830.40.62.20 YUR/L	R AJ2Z L AP2G	CBN	5,95	0,31	5,25	2,95	43,0	R A06.R L A06.L

▼ ØDmin (Min. Bohrung) // ØDmin (min. bore) = 7,2 mm

7,0	25,4	7,2	0,2	+	A07.1835.25.72.20 YUR/L	R ABD2 L AKEW	CBN	6,95	0,36	6,25	3,45	28,0	R A07.R L A07.L
7,0	30,5	7,2	0,2	+	A07.1835.30.72.20 YUR/L	R ACBJ L AJG9	CBN	6,95	0,36	6,25	3,45	33,0	R A07.R L A07.L
7,0	35,6	7,2	0,2	+	A07.1835.35.72.20 YUR/L	R ADK7 L AK9F	CBN	6,95	0,36	6,25	3,45	38,0	R A07.R L A07.L
7,0	40,6	7,2	0,2	+	A07.1835.40.72.20 YUR/L	R AK5S L AF7V	CBN	6,95	0,36	6,25	3,45	43,0	R A07.R L A07.L
7,0	50,8	7,2	0,2	+	A07.1835.50.72.20 YUR/L	R ADDS L AD9D	CBN	6,95	0,36	6,25	3,45	53,0	R A07.R L A07.L

Bestellbeispiel // Order example: **A05.1825.15.52.20 YUR X800** (R = Rechte Ausführung // Right hand version, X800 = Schneidstoff // Grade)