

# Axialstechen in Bohrungen

Geeignet ab Bohrungsdurchmesser 6,2 mm.

# Face Grooving in Bores

For use in bores as of minimum bore diameter 6,2 mm.

Schnittwerte (Start) // Cutting parameters (start)

f	Vc
<b>0,02 mm/U</b>	<b>Seite/Page 429</b>

Passende Klemmhalter auf Seite // Suitable toolholders on page

**28, 31, 36, 42, 45, 50, 51, 53, 55, 56, 58, 61, 62, 64, 65, 66, 67, 68, 69**



**SP**  
**HM**  
**R**

Legende  
Legend **139**

Scan  
QR-Code

Oder besuchen Sie // Or Visit  
[www.simtek.info/cp/759](http://www.simtek.info/cp/759)



Abbildung zeigt / Drawing shows: A06.0100.15.01 AG R



Mehr Informationen zur Kühlmittelzufuhr finden Sie auf Seite 22  
Additional information about through coolant supply on page 22

ØD	w <sup>+0,05</sup>	L2	Kühlmittelzufuhr Through coolant supply	Artikelnummer Part number	Webcode www.simtek.com/webcode	Unsere erste Wahl Our first choice	ØDmin (Min. Bohrung) ØDmin (min. bore)	f	LH	R	tmax	Connectcode www.simtek.com/code
mm	mm	mm				P K M N S	mm	mm	mm	mm	mm	
<b>▼ R = 0,05 mm</b>												
6,0	0,787	15,2	+	<b>A06.0078.15.01.05 AG R/L</b>	R AYU8 L AYU9	X800 X400	6,2	2,95	18,0	0,05	1,8	R A06.R L A06.L <b>Inch</b>
6,0	1,0	15,2	+	<b>A06.0100.15.01.05 AG R/L</b>	R AYU7 L AYU1	X800 X400	6,2	2,95	18,0	0,05	2,0	R A06.R L A06.L
6,0	1,5	15,2	+	<b>A06.0150.15.01.05 AG R/L</b>	R AYVA L AYVB	X800 X400	6,2	2,95	18,0	0,05	3,0	R A06.R L A06.L
<b>▼ R = 0,15 mm</b>												
6,0	1,0	15,2	+	<b>A06.0100.15.01 AG R/L</b>	R AB01 L AH2V	X800 X400	6,2	2,95	18,0	0,15	2,0	R A06.R L A06.L
6,0	1,168	15,2	+	<b>A06.0117.15.01 AG R/L</b>	R ANY2 L AP1G	X800 X400	6,2	2,95	18,0	0,15	2,34	R A06.R L A06.L <b>Inch</b>
6,0	1,5	15,2	+	<b>A06.0150.15.01 AG R/L</b>	R AMN7 L AHFP	X800 X400	6,2	2,95	18,0	0,15	3,0	R A06.R L A06.L <b>Inch</b>
6,0	1,575	15,2	+	<b>A06.0157.15.01 AG R/L</b>	R ANJ5 L AG36	X800 X400	6,2	2,95	18,0	0,15	3,15	R A06.R L A06.L <b>Inch</b>
6,0	1,981	15,2	+	<b>A06.0198.15.01 AG R/L</b>	R AEBQ L APCJ	X800 X400	6,2	2,95	18,0	0,15	3,95	R A06.R L A06.L <b>Inch</b>
6,0	2,0	15,2	+	<b>A06.0200.15.01 AG R/L</b>	R AJ67 L AMKX	X800 X400	6,2	2,95	18,0	0,15	4,0	R A06.R L A06.L <b>Inch</b>
6,0	2,388	15,2	+	<b>A06.0239.15.01 AG R/L</b>	R AF9A L ACZ4	X800 X400	6,2	2,95	18,0	0,15	5,0	R A06.R L A06.L <b>Inch</b>
6,0	2,5	15,2	+	<b>A06.0250.15.01 AG R/L</b>	R AHG4 L AGS3	X800 X400	6,2	2,95	18,0	0,15	5,0	R A06.R L A06.L
6,0	3,0	15,2	+	<b>A06.0300.15.01 AG R/L</b>	R ABX0 L AGAS	X800 X400	6,2	2,95	18,0	0,15	6,0	R A06.R L A06.L
6,0	3,175	15,2	+	<b>A06.0318.15.01 AG R/L</b>	R AM8N L AMGF	X800 X400	6,2	2,95	18,0	0,15	6,0	R A06.R L A06.L <b>Inch</b>

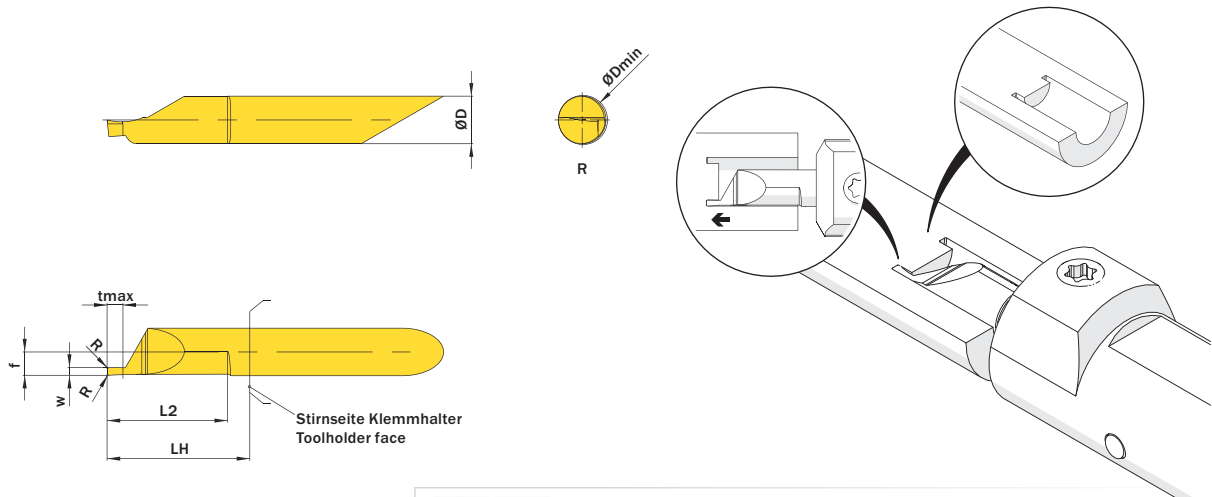
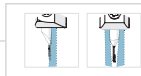
Bestellbeispiel // Order example: **A06.0100.15.01.05 AG R X800** (R = Rechte Ausführung // Right hand version, X800 = Schneidstoff // Grade)