

Abstechen

Verfügbar in verschiedenen Breiten und Winkeln.
 Gesinterte Spanformgeometrie für kontrollierte Spanbildung.

Parting Off

Available in different widths and angles.
 Sintered geometry for improved chip control.

Schnittwerte (Start) // Cutting parameters (start)

f (außen//ext.) 0,12 mm/U	Vc Seite/Page 429
------------------------------	----------------------

Passende Klemmhalter auf Seite // Suitable toolholders on page
 295, 296, 297, 298, 299, 300, 301, 302, 303

SP

HM

Legende
Legend

315

Scan
QR-Code

Oder besuchen Sie // Or Visit
www.simtek.info/cp/526

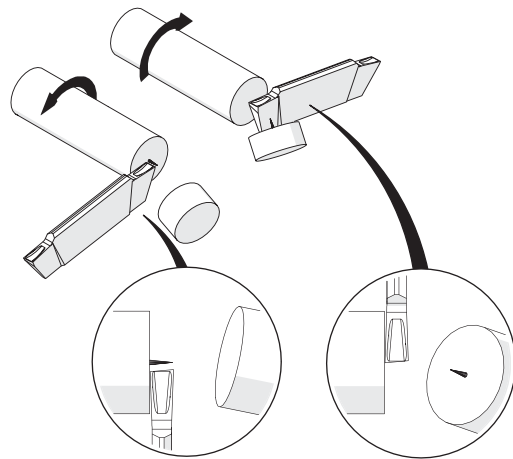
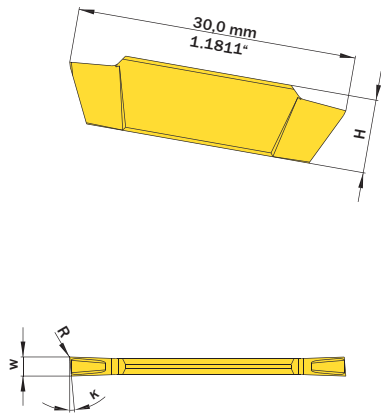

Abbildung zeigt / Drawing shows: G29.5200.32 S R

K	w ^{+0,05} mm	Artikelnummer Part number	Webcode www.simtek.com/webcode	Unsere erste Wahl Our first choice		H mm	R mm	Connectcode www.simtek.com/ccode
				P	K M N S			
▼ w = 2,0 mm								
15°	2,0	G29.1520.32 S R/L	R AMF7 L ANHX	X800	X400	7,9	0,2	G29.02
5°	2,0	G29.5200.32 S R/L	R AMW7 L AGQ9	X800	X400	7,9	0,2	G29.02
8°	2,0	G29.8200.32 S R/L	R AAKB L AFZF	X800	X400	7,9	0,2	G29.02
▼ w = 2,5 mm								
5°	2,5	G29.5250.32 S R/L	R AATN L AHAD	X800	X400	7,9	0,2	G29.02
▼ w = 3,0 mm								
15°	3,0	G29.1530.32 S R/L	R A5CF L AATT	X800	X400	7,9	0,2	G29.03 New
5°	3,0	G29.5300.32 S R/L	R AH07 L ABKE	X800	X400	7,9	0,2	G29.03
8°	3,0	G29.8300.32 S R/L	R AA90 L AM09	X800	X400	7,9	0,2	G29.03
▼ w = 4,0 mm								
5°	4,0	G29.5400.32 S R/L	R AB5F L AFQH	X800	X400	7,9	0,2	G29.03 G29.04

Bestellbeispiel // Order example: **G29.8200.32 S R X800** (R = Rechte Ausführung // Right hand version, X800 = Schneidstoff // Grade)

simturn AX
simturn DX
simturn PX
simturn H2
simturn K2
simturn C4
simturn GX
simturn E3
simturn E12
simturn FX
simturn Decolletage
simturn OA
Index