

Einstecken und Profildrehen

CNC-Konturdrehen mit runder, geschliffener Spanfläche.

Grooving and Profiling

CNC profiling. Ground, round geometry.

Schnittwerte (Start) // Cutting parameters (start)

f (außen//ext.) 0,05 mm/U	f (innen//int.) 0,04 mm/U	Vc Seite/Page 429
-------------------------------------	-------------------------------------	-----------------------------

Passende Klemmhalter auf Seite // Suitable toolholders on page

295, 296, 297, 298, 299, 300, 301, 302, 303



SP Legende
HM Legend

315

Scan
 QR-Code

Oder besuchen Sie // Or Visit
www.simtek.info/cp/519

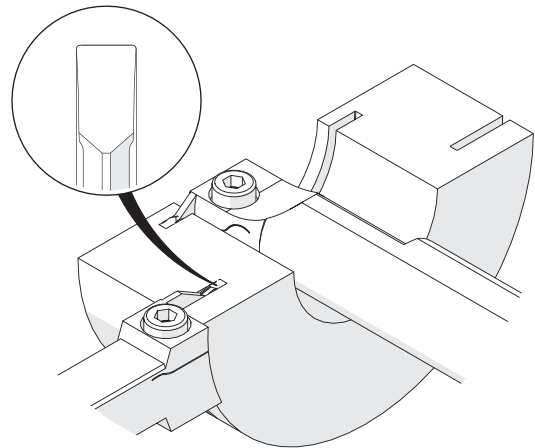
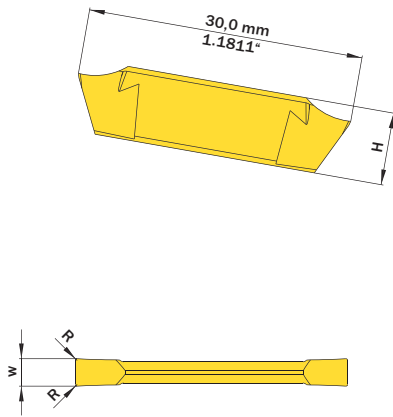

Abbildung zeigt / Drawing shows: G29.0300.10 S

w ^{+0,05} mm	Artikelnummer Part number	Webcode www.simtek.com/webcode	Unsere erste Wahl Our first choice		H mm	R mm	Connectcode www.simtek.com/ccode
			P	K M N S			
2,0	G29.0200.10 S	AH87	X800	X400	7,9	0,2	G29.02
2,5	G29.0250.10 S	AG6S	X800	X400	7,9	0,2	G29.02
3,0	G29.0300.10 S	ACA7	X800	X400	7,9	0,2	G29.03
4,0	G29.0400.10 S	AES9	X800	X400	7,9	0,2	G29.03 G29.04
5,0	G29.0500.10 S	AFY3	X800	X400	7,9	0,2	G29.04
6,0	G29.0600.10 S	AJKN	X800	X400	7,5	0,2	G29.06

Bestellbeispiel // Order example: **G29.0300.10 S X800** (X800 = Schneidstoff // Grade)