

# Nutenstechen

Geeignet ab Bohrungsdurchmesser 7,2 mm.

# Grooving

For use in bores as of minimum bore diameter 7,2 mm.

Schnittwerte (Start) // Cutting parameters (start)

f	Vc
0,02 mm/U	Seite/Page 429

Passende Klemmhalter auf Seite // Suitable toolholders on page

29, 31, 37, 42, 46, 52, 54, 56, 58, 61, 64, 65, 66, 67, 68, 69

Vergleichbare Werkzeuge auf Seite // Similar tools on page

102

**SP** **HM** **R** **Legende** **139**  
**Legend**

Scan QR-Code Oder besuchen Sie // Or Visit  
[www.simtek.info/cp/801](http://www.simtek.info/cp/801)

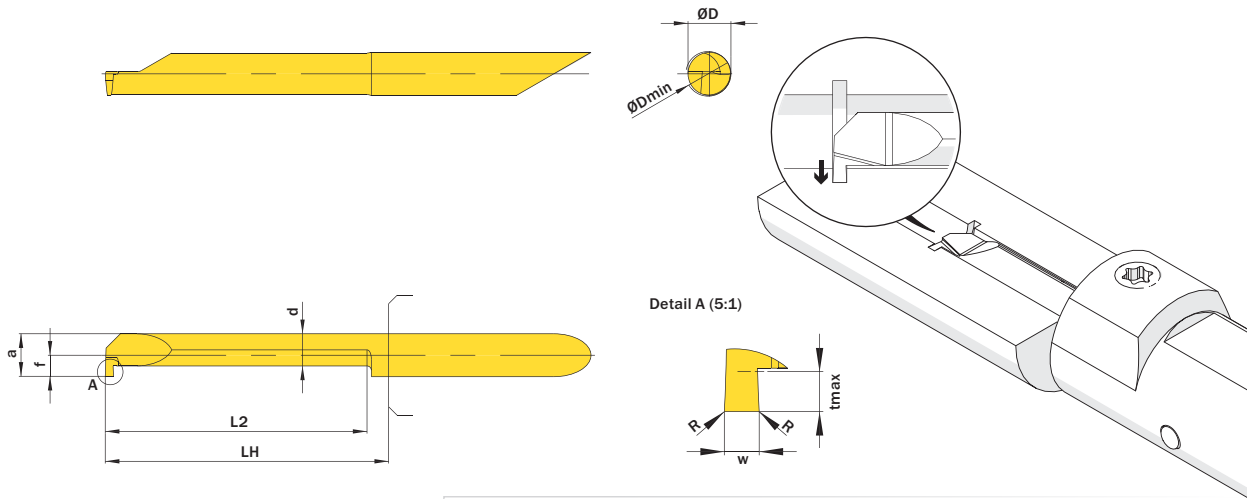

Mehr Informationen zur Kühlmittelzufuhr finden Sie auf Seite 22  
Additional information about through coolant supply on page 22

ØD	w <sup>+0,03</sup>	L2	ØDmin (Min. Bohrung) ØDmin (min. bore)	Kühlmittelzufuhr Through coolant supply	Artikelnummer Part number	Webcode www.simtek.com/webcode	Unsere erste Wahl Our first choice	a	d	f	LH	R	tmax	Connectcode www.simtek.com/code
mm	mm	mm	mm				P K M N S	mm	mm	mm	mm	mm	mm	

Fortgesetzte Tabelle  
Continued Table

Verwandte Werkzeuge finden Sie auch auf der vorhergehenden Seite!  
Related items can be found on the previous page as well!

▼ w = 1,5 mm

7,0	1,5	10,2	7,2	+	A07.0150.10.72 GR/L	R AAN7	L AH5P	X800 X400	6,95	4,25	3,45	13,0	-	2,5	R A07.R	L A07.L
7,0	1,5	15,2	7,2	+	A07.0150.15.72 GR/L	R ACHZ	L APC2	X800 X400	6,95	4,25	3,45	18,0	-	2,5	R A07.R	L A07.L
7,0	1,5	20,3	7,2	+	A07.0150.20.72 GR/L	R AHXA	L ADJB	X800 X400	6,95	4,25	3,45	23,0	-	2,5	R A07.R	L A07.L
7,0	1,5	25,4	7,2	+	A07.0150.25.72 GR/L	R AJW7	L ANDE	X800 X400	6,95	4,25	3,45	28,0	-	2,5	R A07.R	L A07.L
7,0	1,5	30,5	7,2	+	A07.0150.30.72 GR/L	R ACNN	L ACEZ	X800 X400	6,95	4,25	3,45	33,0	-	2,5	R A07.R	L A07.L
7,0	1,5	35,6	7,2	+	A07.0150.35.72 GR/L	R AGAX	L AG9E	X800 X400	6,95	4,25	3,45	38,0	-	2,5	R A07.R	L A07.L
7,0	1,5	40,6	7,2	+	A07.0150.40.72 GR/L	R AMH7	L AKM9	X800 X400	6,95	4,25	3,45	43,0	-	2,5	R A07.R	L A07.L

▼ w = 1,575 mm

7,0	1,575	10,2	7,2	+	A07.0157.10.72 GR/L	R AP08	L ACYH	X800 X400	6,95	4,25	3,45	13,0	-	2,5	R A07.R	L A07.L	inch
7,0	1,575	15,2	7,2	+	A07.0157.15.72 GR/L	R AAND	L AA4C	X800 X400	6,95	4,25	3,45	18,0	-	2,5	R A07.R	L A07.L	inch
7,0	1,575	20,3	7,2	+	A07.0157.20.72 GR/L	R AN5Y	L AD2K	X800 X400	6,95	4,25	3,45	23,0	-	2,5	R A07.R	L A07.L	inch
7,0	1,575	25,4	7,2	+	A07.0157.25.72 GR/L	R AKKT	L AN6P	X800 X400	6,95	4,25	3,45	28,0	-	2,5	R A07.R	L A07.L	inch
7,0	1,575	30,5	7,2	+	A07.0157.30.72 GR/L	R ABPX	L AHW3	X800 X400	6,95	4,25	3,45	33,0	-	2,5	R A07.R	L A07.L	inch
7,0	1,575	35,6	7,2	+	A07.0157.35.72 GR/L	R AMP7	L AMB3	X800 X400	6,95	4,25	3,45	38,0	-	2,5	R A07.R	L A07.L	inch
7,0	1,575	40,6	7,2	+	A07.0157.40.72 GR/L	R AFZG	L AKJZ	X800 X400	6,95	4,25	3,45	43,0	-	2,5	R A07.R	L A07.L	inch

Verwandte Werkzeuge finden Sie auch auf der folgenden Seite!  
Related items can be found on the following page as well!

Fortgesetzte Tabelle  
Continued Table

Bestellbeispiel // Order example: A07.0150.15.72 GR X800 (R = Rechte Ausführung // Right hand version, X800 = Schneidstoff // Grade)