

# Allgemeines Nutfräsen

Nutfräsen gerader Nutformen.  
 Geeignet ab Bohrungsdurchmesser 28,0 mm.

# General Groove Milling

General groove milling.  
 For use in bores as of minimum bore diameter 28,0 mm.

Schnittwerte (Start) // Cutting parameters (start)		
fzm <b>0,04 mm</b>	hmax <b>0,05 mm</b>	Vc <b>Seite/Page 638</b>
Passende Klemmhalter auf Seite // Suitable toolholders on page <b>556, 557, 558, 559, 560, 561, 563</b>		
Vergleichbare Werkzeuge auf Seite // Similar tools on page <b>461</b>		
Bitte Hinweise im Anhang beachten // Please read add. notes <b>ALL (Seite/Page 645), H01 (Seite/Page 646), H05 (Seite/Page 648)</b>		

SP

Legende

HM

Legend

Scan QR-Code

**650**

Oder besuchen Sie // Or visit  
[www.simtek.info/cp/381](http://www.simtek.info/cp/381)

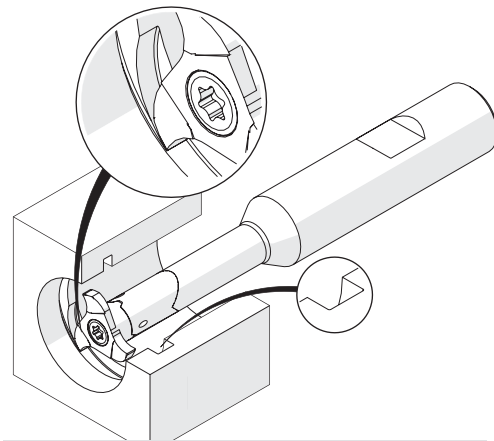
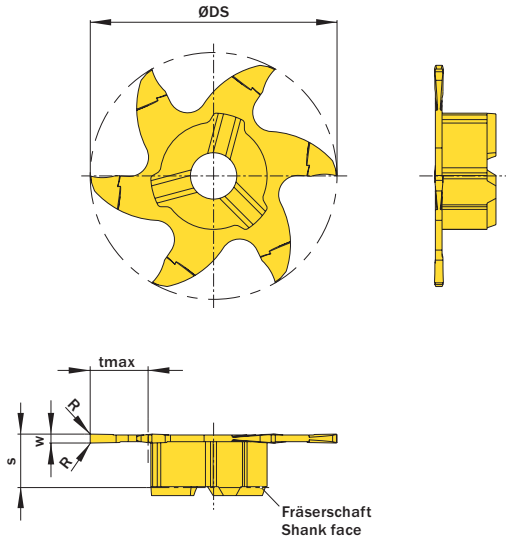

Illustration zeigt beispielhafte Anwendungsmöglichkeit mit ähnlichem Werkzeug.  
 Image shows exemplary application possibility with similar tool.

Abbildung zeigt / Drawing shows: V06.0100.010.28 G

w <sup>+0,02</sup> mm	Nutnennbreite Nominal width of groove mm	R mm	ØDmin (Min. Bohrung) ØDmin (min. bore) mm	Artikelnummer Part number	Webcode www.simtek.com/webcode	Unsere erste Wahl Our first choice		tmax mm	S mm	ØDS mm	Anzahl Schneiden Number of cutting edges	Connectcode www.simtek.com/code
						P M K N S						
1,0	-	0,1	28,0	<b>V06.0100.010.28 G</b>	AASZ	X800	GT42	6,5	6,0	27,7	6	VD14.0 VD14.3
1,2	-	0,1	28,0	<b>V06.0120.010.28 G</b>	AKEZ	X800	GT42	6,5	6,1	27,7	6	VD14.0 VD14.3
1,5	-	0,1	28,0	<b>V06.0150.010.28 G</b>	AD7U	X800	GT42	6,5	6,4	27,7	6	VD14.0 VD14.3
2,0	-	0,2	28,0	<b>V06.0200.020.28 G</b>	AN7K	X800	GT42	6,5	6,4	27,7	6	VD14.0 VD14.3
2,5	-	0,2	28,0	<b>V06.0250.020.28 G</b>	AH3Y	X800	GT42	6,5	6,4	27,7	6	VD14.0 VD14.3
3,0	-	0,2	28,0	<b>V06.0300.020.28 G</b>	APW3	X800	GT42	6,5	6,4	27,7	6	VD14.0 VD14.3
4,0	-	0,2	28,0	<b>V06.0400.020.28 G</b>	AP00	X800	GT42	6,5	6,4	27,7	6	VD14.0 VD14.3
5,0	-	0,2	28,0	<b>V06.0500.020.28 G</b>	AP9Z	X800	GT42	6,5	6,4	27,7	6	VD14.0 VD14.3
6,0	-	0,2	28,0	<b>V06.0600.020.28 G</b>	AP90	X800	GT42	6,5	6,4	27,7	6	VD14.0 VD14.3

Bestellbeispiel // Order example: **V06.0400.020.28 G X800** (X800 = Schneidstoff // Grade)



V06. w, 1/100 mm, 4 Stellen/Digits . R, 1/100 mm, 3 Stellen/Digits .28 Toleranz // Tolerance  
 Beispielartikelnummer // Example Part number: **V06.0179.030.28 XG**