

Stechen, schmale Sicherungsringnuten, reduzierte Stechtiefe

Sicherungsringnuten, vgl. DIN 471/472 sowie DIN 983/984.
Reduzierte Stechtiefe.

Grooving, Circlip Ring Grooves, Slim Widths, With Reduced Cutting depth

Circlip ring grooves comp. to DIN 471/472 and DIN 983/984.
Reduced cutting depth.

Schnittwerte (Start) // Cutting parameters (start)

f	Vc
0,04 mm/U	Seite/Page 429

Passende Klemmhalter auf Seite // Suitable toolholders on page
361, 362, 363, 364, 365, 367, 368

SP
HM
Legende
Legend
389

 Scan QR-Code
 Oder besuchen Sie // Or Visit www.simtek.info/cp/499

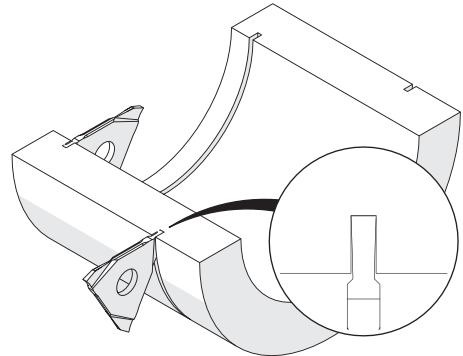
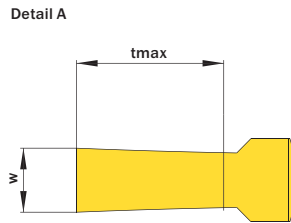
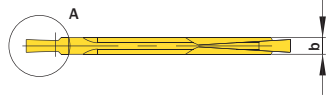
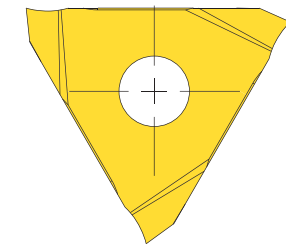

Abbildung zeigt / Drawing shows: E12.1094.00 Z

b ±0,02 mm	Nennbreite Nominal width of mm	Artikelnummer Part number	Webcode www.simtek.com/webcode	Unsere erste Wahl Our first choice	tmax mm	w ^{-0,05} mm	Connectcode www.simtek.com/code
1,3	0,34	E12.1034.00 Z	AHE9	X808 X408	0,6	0,4	E12.A1 E12.A2
1,3	0,44	E12.1044.00 Z	AJAV	X808 X408	0,7	0,5	E12.A1 E12.A2
1,3	0,5	E12.1050.00 Z	ANE0	X808 X408	0,9	0,57	E12.A1 E12.A2
1,3	0,54	E12.1054.00 Z	AHZF	X808 X408	0,8	0,6	E12.A1 E12.A2
1,3	0,6	E12.1060.00 Z	APXN	X808 X408	1,1	0,67	E12.A1 E12.A2
1,3	0,64	E12.1064.00 Z	AC2C	X808 X408	1,0	0,7	E12.A1 E12.A2
1,3	0,7	E12.1070.00 Z	AD4M	X808 X408	1,7	0,77	E12.A1 E12.A2
1,3	0,74	E12.1074.00 Z	ANH3	X808 X408	1,7	0,8	E12.A1 E12.A2
1,3	0,8	E12.1080.00 Z	ADDH	X808 X408	2,3	0,87	E12.A1 E12.A2
1,3	0,85	E12.1085.00 Z	AAUW	X808 X408	2,3	0,91	E12.A1 E12.A2
1,3	0,9	E12.1090.00 Z	ADHX	X808 X408	2,3	0,97	E12.A1 E12.A2
1,3	0,94	E12.1094.00 Z	AMUD	X808 X408	2,3	1,0	E12.A1 E12.A2
1,3	1,0	E12.1100.00 Z	AB93	X808 X408	2,3	1,07	E12.A1 E12.A2
1,3	1,05	E12.1105.00 Z	AH3J	X808 X408	2,3	1,12	E12.A1 E12.A2
1,3	1,1	E12.1115.00 Z	AEHY	X808 X408	2,5	1,22	E12.A1 E12.A2

Bestellbeispiel // Order example: **E12.1094.00 Z X808** (X808 = Schneidstoff // Grade)

simturn AX
simturn DX
simturn PX
simturn H2
simturn H2
simturn K2
simturn C4
simturn GX
simturn E3
simturn E12
simturn FX
simturn Decoletage
simturn OA
Index