

Klemmhalter, Innenbearbeitung, Rundschaft

Rundschaft mit innerer Kühlmittelzufuhr für die Größen A08 und A10.

Toolholder, Internal Applications, Round Shank

Round shank with through coolant for size A08 and A10.

Anzugsmoment (Schraube) // Tightening torque (screw)

7,0 Nm

Bitte Hinweise im Anhang beachten // Please read add. notes

MASTER (Seite/Page 137)



Legende
Legend

139



Scan
QR-Code

Oder besuchen Sie // Or Visit
www.simtek.info/cp/785

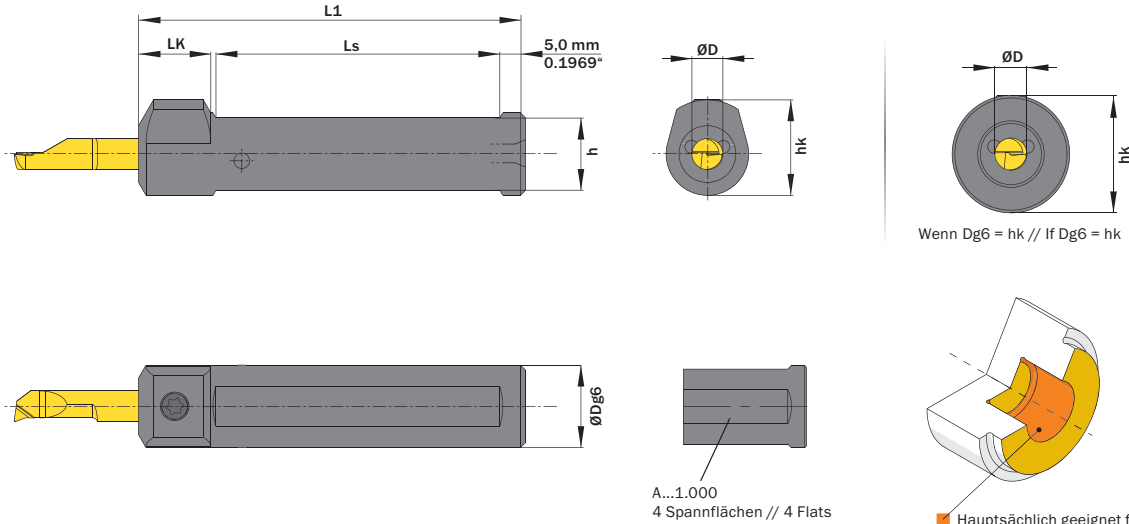

Wenn Dg6 = hk // If Dg6 = hk

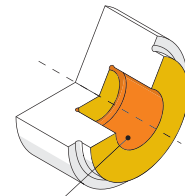

- Hauptsächlich geeignet für diese Flächen
Mainly designed for these surfaces
- Je nach Schneidplatte ebenfalls möglich
Also possible depending on insert type

ØD	ØDg6	Artikelnummer Part number	Webcode www.simtek.com/webcode	h	hk	L1	LK	Ls	Anzahl Spannflächen Number of flats	Schraube Screw	Schraubenschlüssel Screw driver	Connectcode www.simtek.com/code
mm	mm			mm	mm	mm	mm	mm				

Fortgesetzte Tabelle
Continued Table

Verwandte Werkzeuge finden Sie auch auf der vorhergehenden Seite!
Related items can be found on the previous page as well!

▼ ØD = 8,0 mm													
8,0	15,875	A08.0.625	AHYF	13,88	19,44	75,0	14,0	55,0	2	A M6x7,5 T15F	T15F	A08	Inch
8,0	16,0	A08.0016	AAAV	14,0	19,5	75,0	14,0	55,0	2	A M6x7,5 T15F	T15F	A08	
8,0	19,05	A08.0.750	AAKN	17,05	24,0	110,0	14,0	90,0	2	A M6x7,5 T15F	T15F	A08	Inch
8,0	20,0	A08.0020	AD6N	18,0	25,0	90,0	14,0	70,0	2	A M6x7,5 T15F	T15F	A08	
8,0	25,0	A08.0025	AMAS	23,0	25,0	110,0	-	90,0	2	A M6x7,5 T15F	T15F	A08	
8,0	25,4	A08.1.000	AAQJ	23,4	25,4	110,0	-	90,0	4	A M6x7,5 T15F	T15F	A08	Inch
▼ ØD = 10,0 mm													
10,0	19,05	A10.0.750	AEJ2	17,05	24,0	110,0	14,0	90,0	2	A M6x7,5 T15F	T15F	A10L A10.R	Inch
10,0	20,0	A10.0020	AGQZ	18,0	25,0	90,0	14,0	70,0	2	A M6x7,5 T15F	T15F	A10L A10.R	
10,0	25,0	A10.0025	ABB8	23,0	25,0	110,0	-	90,0	2	A M6x7,5 T15F	T15F	A10L A10.R	
10,0	25,4	A10.1.000	AHAY	23,4	25,4	110,0	-	90,0	4	A M6x7,5 T15F	T15F	A10L A10.R	Inch

Verwandte Werkzeuge finden Sie auch auf der folgenden Seite!
Related items can be found on the following page as well!

Fortgesetzte Tabelle
Continued Table

Bestellbeispiel // Order example: **A10.0020**