

Ausdrehen, Hartbearbeitung und WIPER Geometrie

In Verbindung mit einem CBN-Schneidstoff besonders geeignet für die Hartbearbeitung ab Bohrungsdurchmesser 4,2 mm.

Boring, Hard Part Turning plus WIPER-Geometry

First choice for hard part turning applications in bores as of bore diameter 4,2 mm in combination with our CBN grades.

Schnittwerte (Start) // Cutting parameters (start)

f	Vc
0,02 mm/U	Seite/Page 429

Passende Klemmhalter auf Seite // Suitable toolholders on page

26, 31, 32, 33, 34, 40, 41, 43, 50, 51, 53, 55, 56, 57, 60, 62, 63, 65, 66, 67, 68, 69

Vergleichbare Werkzeuge auf Seite // Similar tools on page

88



Legende Legend 139



Scan QR-Code

Oder besuchen Sie // Or Visit www.simtek.info/cp/1053

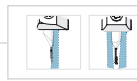
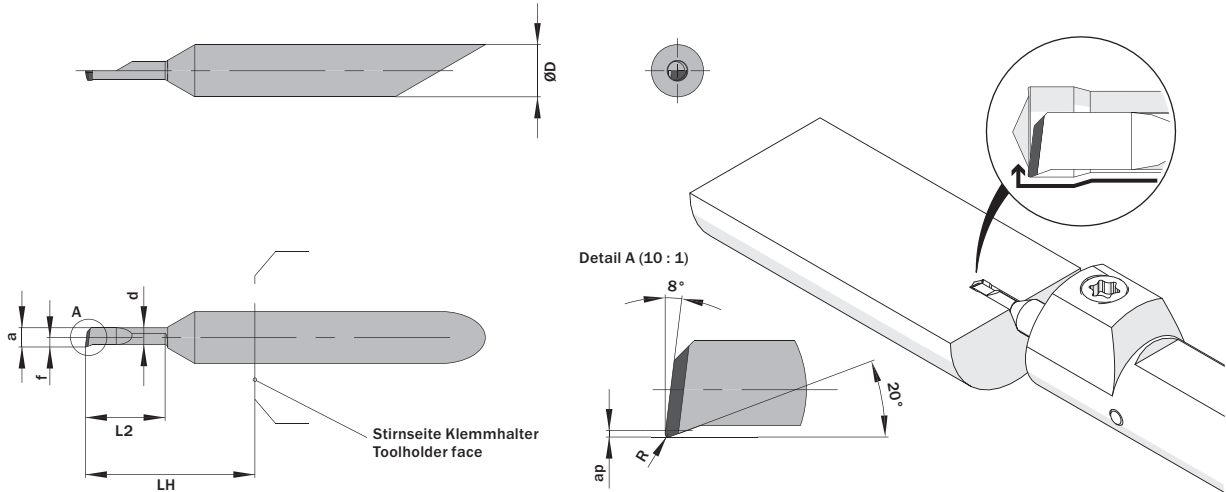

Mehr Informationen zur Kühlmittelzufuhr finden Sie auf Seite 22
Additional information about through coolant supply on page 22

ØD	L2	ØDmin (Min. Bohrung) ØDmin (min. bore)	R	Kühlmittelzufuhr Through coolant supply	Artikelnummer Part number	Webcode www.simtek.com/webcode	Unsere erste Wahl Our first choice	a	ap	d	f	LH	Connectcode www.simtek.com/code
mm	mm	mm	mm				H	mm	mm	mm	mm	mm	

Fortgesetzte Tabelle
Continued Table

Verwandte Werkzeuge finden Sie auch auf der vorhergehenden Seite!
Related items can be found on the previous page as well!

▼ ØDmin (Min. Bohrung) // ØDmin (min. bore) = 3,7 mm													
4,0	10,2	3,7	0,15	-	A04.1817.10.37.15 YUR	A54H	CBN	3,45	0,18	3,05	1,7	13,0	A04.R new
4,0	10,2	3,7	0,15	+	A04.1C17.10.37.15 YUR/L	R AF4J L AHZV	CBN	3,45	0,18	3,05	1,95	13,0	R A04C.R L A04C.L
4,0	15,2	3,7	0,15	-	A04.1817.15.37.15 YUR/L	R ABVW L AFNM	CBN	3,45	0,18	3,05	1,7	18,0	R A04.R L A04.L
4,0	15,2	3,7	0,15	+	A04.1C17.15.37.15 YUR/L	R AJ9Y L ABDU	CBN	3,45	0,18	3,05	1,95	18,0	R A04C.R L A04C.L
4,0	20,3	3,7	0,15	-	A04.1817.20.37.15 YUR	A54K	CBN	3,45	0,18	3,05	1,7	23,0	A04.R new
4,0	20,3	3,7	0,15	+	A04.1C17.20.37.15 YUR/L	R AHN6 L ABFZ	CBN	3,45	0,18	3,05	1,95	23,0	R A04C.R L A04C.L
4,0	25,4	3,7	0,1	-	A04.1817.25.37.10 YUR	A54N	CBN	3,45	0,18	3,05	1,7	28,0	A04.R new
4,0	25,4	3,7	0,1	+	A04.1C17.25.37.10 YUR/L	R AK2Z L AGKZ	CBN	3,45	0,18	3,05	1,95	28,0	R A04C.R L A04C.L
4,0	25,4	3,7	0,15	-	A04.1817.25.37.15 YUR	A54Q	CBN	3,45	0,18	3,05	1,7	28,0	A04.R new
4,0	25,4	3,7	0,15	+	A04.1C17.25.37.15 YUR/L	R AM56 L ATWA	CBN	3,45	0,18	3,05	1,95	28,0	R A04C.R L A04C.L
▼ ØDmin (Min. Bohrung) // ØDmin (min. bore) = 4,2 mm													
4,0	10,2	4,2	0,15	+	A04.1820.10.42.15 YUR/L	R AH9U L AH6F	CBN	3,95	0,21	3,45	1,95	13,0	R A04C.R L A04C.L
4,0	15,2	4,2	0,15	+	A04.1820.15.42.15 YUR/L	R AJ94 L AMC8	CBN	3,95	0,21	3,45	1,95	18,0	R A04C.R L A04C.L
4,0	20,3	4,2	0,15	+	A04.1820.20.42.15 YUR/L	R AHVV L ABZS	CBN	3,95	0,21	3,45	1,95	23,0	R A04C.R L A04C.L
4,0	25,4	4,2	0,15	+	A04.1820.25.42.15 YUR/L	R AKJE L ACN3	CBN	3,95	0,21	3,45	1,95	28,0	R A04C.R L A04C.L
4,0	10,2	4,2	0,15	+	A04.2020.10.42.15 YUR/L	R AQQC L A4X3	CBN	3,95	0,21	3,45	1,95	13,0	R A04.R L A04.L new

Verwandte Werkzeuge finden Sie auch auf der folgenden Seite!
Related items can be found on the following page as well!

Fortgesetzte Tabelle
Continued Table

Bestellbeispiel // Order example: A04.1817.15.37.15 YUR CBN8 (R = Rechte Ausführung // Right hand version, CBN8 = Schneidstoff // Grade)