

Fräsen von Scheibenfedernuten

Fräsen von Scheibenfedernuten (DIN6888).
Aufnahme nach DIN 6535 HA und DIN 1835 A.

Keyway milling

Keyway milling according to DIN6888.
Shank according to DIN 6535 HA and DIN 1835 A.

Schnittwerte (Start) // Cutting parameters (Start)		
fzm 0,02 mm	hmax 0,03 mm	Vc Seite/Page 638

Bitte Hinweise im Anhang beachten // Please read add. notes
ALL (Seite/Page 645)



SP Legende
HM Legend
650
Scan QR-Code Oder besuchen Sie // Or Visit
www.simtek.info/cp/304

Weldon-Aufnahme auf Anfrage erhältlich.
Weldon fixation available upon request.

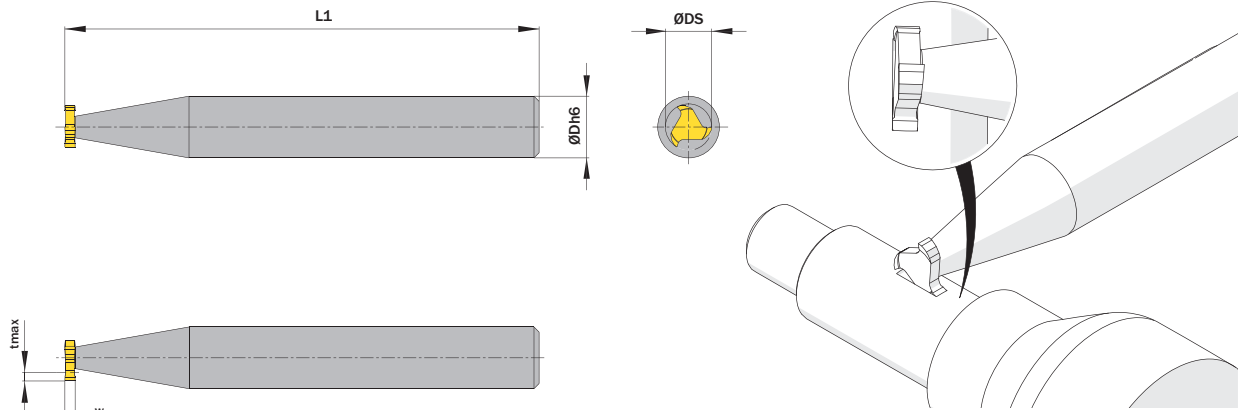

Illustration zeigt beispielhafte Anwendungsmöglichkeit mit ähnlichem Werkzeug.
Image shows exemplary application possibility with similar tool.

Abbildung zeigt / Drawing shows: MA3.100.09.06.00 AS

w ^{e8} mm	ØDS mm	ØDh6 mm	Artikelnummer Part number	Webcode www.simtek.com/webcode	Unsere erste Wahl Our first choice P M K N S	Anzahl Schneiden Number of cutting edges	L1 mm	tmax mm	Aufnahme nach Shank according to	Connectcode www.simtek.com/code
▼ ØDS = 4,5 mm										
1,0	4,5	6,0	MA3.100.04.06.00 AS	AKØY	X800 GT42	3	50,0	1,0	DIN 6535 HA	-
▼ ØDS = 7,5 mm										
1,5	7,5	8,0	MA3.150.07.08.00 AS	ANPA	X800 GT42	3	50,0	2,0	DIN 6535 HA	-
2,0	7,5	8,0	MA3.200.07.08.00 AS	AK6Z	X800 GT42	3	50,0	1,8	DIN 6535 HA	-
▼ ØDS = 10,5 mm										
2,0	10,5	12,0	MA3.200.10.12.00 AS	AEH6	X800 GT42	3	60,0	2,9	DIN 6535 HA	-
2,5	10,5	12,0	MA3.250.10.12.00 AS	ACMK	X800 GT42	3	60,0	2,9	DIN 6535 HA	-
3,0	10,5	12,0	MA3.300.10.12.00 AS	AM42	X800 GT42	3	60,0	2,5	DIN 6535 HA	-
▼ ØDS = 13,5 mm										
3,0	13,5	16,0	MA3.300.13.16.00 AS	AF2J	X800 GT42	3	70,0	3,8	DIN 1835 A	-
4,0	13,5	16,0	MA3.400.13.16.00 AS	AEØ1	X800 GT42	3	70,0	3,5	DIN 1835 A	-
▼ ØDS = 16,5 mm										
3,0	16,5	16,0	MA3.300.16.16.00 AS	ADT5	X800 GT42	3	70,0	5,3	DIN 1835 A	-
4,0	16,5	16,0	MA3.400.16.16.00 AS	AJXW	X800 GT42	3	70,0	5,0	DIN 1835 A	-
5,0	16,5	16,0	MA3.500.16.16.00 AS	AGA J	X800 GT42	3	70,0	4,5	DIN 1835 A	-
▼ ØDS = 19,5 mm										
4,0	19,5	16,0	MA3.400.19.16.00 AS	ANKE	X800 GT42	3	70,0	6,0	DIN 1835 A	-
5,0	19,5	16,0	MA3.500.19.16.00 AS	AMØX	X800 GT42	3	70,0	5,5	DIN 1835 A	-
6,0	19,5	16,0	MA3.600.19.16.00 AS	AB59	X800 GT42	3	70,0	5,1	DIN 1835 A	-
▼ ØDS = 22,5 mm										
5,0	22,5	16,0	MA3.500.22.16.00 AS	ANVG	X800 GT42	3	70,0	7,0	DIN 1835 A	-
6,0	22,5	16,0	MA3.600.22.16.00 AS	AHC5	X800 GT42	3	70,0	6,6	DIN 1835 A	-
8,0	22,5	16,0	MA3.800.22.16.00 AS	ADG7	X800 GT42	3	70,0	6,2	DIN 1835 A	-
▼ ØDS = 25,5 mm										
6,0	25,5	16,0	MA3.600.25.16.00 AS	AH8A	X800 GT42	3	70,0	7,6	DIN 1835 A	-

Bestellbeispiel // Order example: **MA3.150.07.08.00 AS X800** (X800 = Schneidstoff // Grade)