

Nutenstechen

Für allgemeines Nutenstechen und für Sicherungsringnuten.
Geeignet ab Bohrungsdurchmesser 14,0 mm.

Grooving

For general grooving as well as for circlip ring grooving.
For use in bores as of minimum bore diameter 14,0 mm.

Schnittwerte (Start) // Cutting parameters (start)	
f 0,02 mm/U	Vc Seite/Page 429

Passende Klemmhalter auf Seite // Suitable toolholders on page
158, 161, 164

Vergleichbare Werkzeuge auf Seite // Similar tools on page
175

SP

HM

R

Legende
Legend **213**

Oder besuchen Sie // Or Visit
www.simtek.info/cp/841

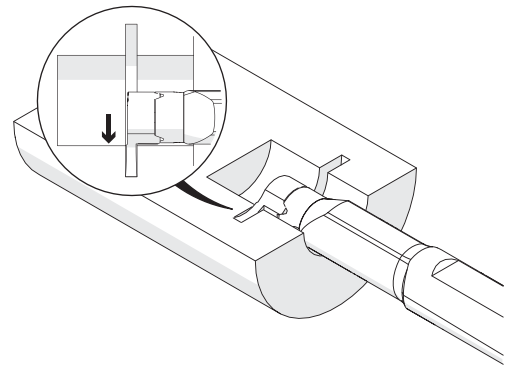
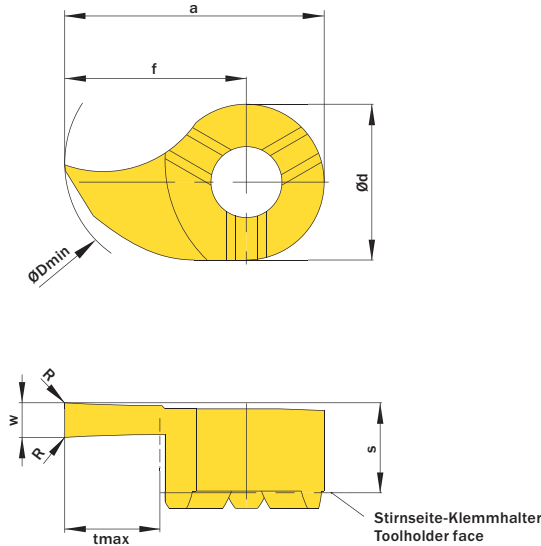

w ^{+0,03}	Nutnenbreite Nominal width of groove	ØDmin (Min. Bohrung) ØDmin (min. bore)	Artikelnummer Part number	Webcode www.simtek.com/webcode	Unsere erste Wahl Our first choice	a	Ød	f	R	S	tmax	Connectcode www.simtek.com/code
mm	mm	mm			P K M N S	mm	mm	mm	mm	mm	mm	

Fortgesetzte Tabelle // Continued Table
 Verwandte Werkzeuge finden Sie auch auf der vorhergehenden Seite!
 Related Items can be found on the previous page as well!

0,73	0,7	14,0	D14.0070.00 ZR/L	R AB83 L AMAH X800 X400	13,5	9,0	9,0	-	5,2	1,2	D14	
0,787	-	14,0	D14.0078.00 ZR/L	R AFD3 L AJØC X800 X400	13,5	9,0	9,0	-	5,2	1,3	D14	inch
0,83	0,8	14,0	D14.0080.00 ZR/L	R AF8T L AMXS X800 X400	13,5	9,0	9,0	-	5,2	1,3	D14	
0,86	-	14,0	D14.0086.00 ZR/L	R AJV2 L ADKX X800 X400	13,5	9,0	9,0	-	5,2	1,5	D14	
0,93	0,9	14,0	D14.0090.00 ZR/L	R AEAM L ADZA X800 X400	13,5	9,0	9,0	-	5,2	1,5	D14	
1,0	-	14,0	D14.0100.00 ZR/L	R APFC L AMY9 X800 X400	13,5	9,0	9,0	-	5,2	4,0	D14	
1,2	1,1	14,0	D14.0110.00 GR/L	R AK84 L AM81 X800 X400	13,5	9,0	9,0	-	5,3	4,0	D14	
1,4	1,3	14,0	D14.0130.00 GR/L	R ADGC L AAFB X800 X400	13,5	9,0	9,0	-	5,3	4,0	D14	
1,5	-	14,0	D14.0150.00 GR/L	R AK6Q L AAJG X800 X400	13,5	9,0	9,0	-	5,3	4,0	D14	
1,575	-	14,0	D14.0157.00 GR/L	R ANYM L AFDN X800 X400	13,5	9,0	9,0	-	5,3	4,0	D14	inch
1,7	1,6	14,0	D14.0160.00 GR/L	R AJTA L AC77 X800 X400	13,5	9,0	9,0	-	5,3	4,0	D14	
2,0	-	14,0	D14.0200.00 GR/L	R AG8N L AMW3 X800 X400	13,5	9,0	9,0	-	5,3	4,0	D14	
2,388	-	14,0	D14.0238.00 GR/L	R ACPC L AB79 X800 X400	13,5	9,0	9,0	-	5,3	4,0	D14	inch
2,5	-	14,0	D14.0250.00 GR/L	R AHSS L AA56 X800 X400	13,5	9,0	9,0	-	5,3	4,0	D14	
3,0	-	14,0	D14.0300.00 GR/L	R AFFU L AHHA X800 X400	13,5	9,0	9,0	-	5,3	4,0	D14	
3,175	-	14,0	D14.0318.00 GR/L	R AKKN L APJD X800 X400	13,5	9,0	9,0	-	5,3	4,0	D14	inch

Verwandte Werkzeuge finden Sie auch auf der folgenden Seite!
 Related Items can be found on the following page as well!

Fortgesetzte Tabelle
Continued Table

Bestellbeispiel // Order example: **D14.0200.00 GR X800** (R = Rechte Ausführung // Right hand version, X800 = Schneidstoff // Grade)