

# Gewindedrehen, Metrisches ISO Vollprofil

Herstellung des vollständigen Gewindeprofils mit erforderlicher Tiefe.

## Threading, Metric ISO Full Profile

For a complete thread profile with correct depth.

Schnittwerte (Start) // Cutting parameters (start)
Anzahl Durchgänge // Number of passes <b>10 - 16</b>
Empf. Zustellungsart // Recom. infeed method <b>Flankenzustellung // Flank infeed (Seite/Page 433)</b>
Vc <b>Seite/Page 429</b>

Passende Klemmhalter auf Seite // Suitable toolholders on page  
**158, 159, 161, 163, 164**



**SP** **HM** **R** Legende Legend **213**

Scan QR-Code Oder besuchen Sie // Or Visit [www.simtek.info/cp/882](http://www.simtek.info/cp/882)



Abbildung zeigt / Drawing shows: D11.0815.02 MR

HC	Steigung TP Pitch TP	Artikelnummer Part number	Webcode <a href="http://www.simtek.com/webcode">www.simtek.com/webcode</a>	Unsere erste Wahl Our first choice	a	b	HA	HB	Ød	ØDmin (Min. Bohrung) ØDmin (min. bore)	f	S	Connectcode <a href="http://www.simtek.com/code">www.simtek.com/code</a>
mm	mm			P K M N S	mm	mm	mm	mm	mm	mm	mm	mm	

Fortgesetzte Tabelle  
Continued Table

Verwandte Werkzeuge finden Sie auch auf der vorhergehenden Seite!  
Related items can be found on the previous page as well!

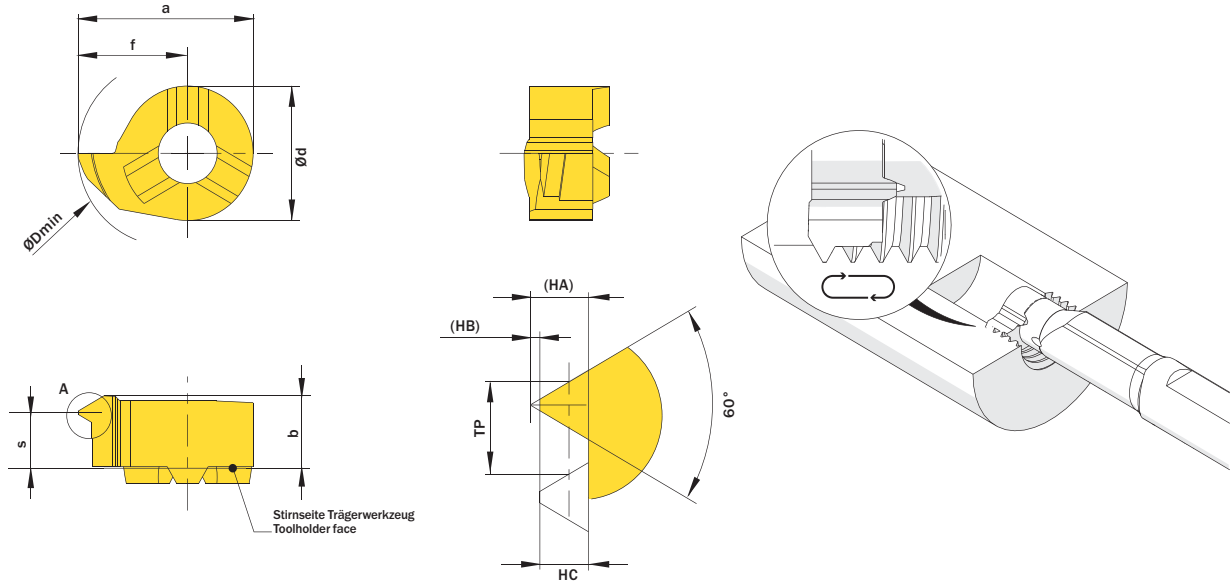
▼ ØDmin (Min. Bohrung) // ØDmin (min. bore) = 14,0 mm														
0,271	0,5	<b>D14.0205.02 MR/L</b>	R AG11 L AAM6	X800 X400	13,5	5,4	0,325	0,054	9,0	14,0	9,0	4,8	D14	upd
0,541	1,0	<b>D14.0510.02 MR/L</b>	R AGVA L AN3Z	X800 X400	13,5	5,4	0,65	0,108	9,0	14,0	9,0	4,7	D14	upd
0,812	1,5	<b>D14.0815.02 MR/L</b>	R AAPD L AHEZ	X800 X400	13,5	5,4	0,974	0,162	9,0	14,0	9,0	4,3	D14	upd
1,083	2,0	<b>D14.1020.02 MR/L</b>	R ABSD L AMJS	X800 X400	13,5	5,4	1,299	0,217	9,0	14,0	9,0	4,2	D14	upd
1,353	2,5	<b>D14.1325.02 MR/L</b>	R AFMØ L APW6	X800 X400	13,5	5,4	1,624	0,271	9,0	14,0	9,0	3,65	D14	upd
▼ ØDmin (Min. Bohrung) // ØDmin (min. bore) = 16,0 mm														
0,541	1,0	<b>D16.0510.02 MR/L</b>	R ACØ7 L ACXP	X800 X400	15,7	5,5	0,65	0,108	11,0	16,0	10,2	4,8	D16	upd
0,812	1,5	<b>D16.0815.02 MR/L</b>	R ADSQ L AGTH	X800 X400	15,7	5,5	0,974	0,162	11,0	16,0	10,2	4,3	D16	upd
1,083	2,0	<b>D16.1020.02 MR/L</b>	R AHC8 L ANXE	X800 X400	15,7	5,5	1,299	0,217	11,0	16,0	10,2	4,05	D16	upd
1,353	2,5	<b>D16.1325.02 MR/L</b>	R AMW1 L AG5U	X800 X400	15,7	5,5	1,624	0,271	11,0	16,0	10,2	4,2	D16	upd
1,624	3,0	<b>D16.1630.02 MR/L</b>	R AKHY L AN34	X800 X400	15,7	5,5	1,949	0,325	11,0	16,0	10,2	4,0	D16	upd
1,894	3,5	<b>D16.1835.02 MR/L</b>	R AANW L AG41	X800 X400	15,7	5,5	2,273	0,379	11,0	16,0	10,2	3,9	D16	upd
2,165	4,0	<b>D16.2140.02 MR/L</b>	R AD32 L AEED	X800 X400	15,7	5,5	2,598	0,433	11,0	16,0	10,2	3,6	D16	upd

Bestellbeispiel // Order example: **D14.0815.02 MR X800** (R = Rechte Ausführung // Right hand version, X800 = Schneidstoff // Grade)