

Nutenstechen

Geeignet ab Bohrungsdurchmesser 5,2 mm.

Grooving

For use in bores as of minimum bore diameter 5,2 mm.

Schnittwerte (Start) // Cutting parameters (start)	
f 0,02 mm/U	Vc Seite/Page 429

Passende Klemmhalter auf Seite // Suitable toolholders on page 27, 31, 33, 35, 41, 44, 50, 51, 53, 55, 56, 57, 61, 62, 63, 65, 66, 67, 68, 69

Vergleichbare Werkzeuge auf Seite // Similar tools on page 102
--

SP

HM

R

Legende
Legend **139**

Scan QR-Code Oder besuchen Sie // Or Visit
www.simtek.info/cp/795

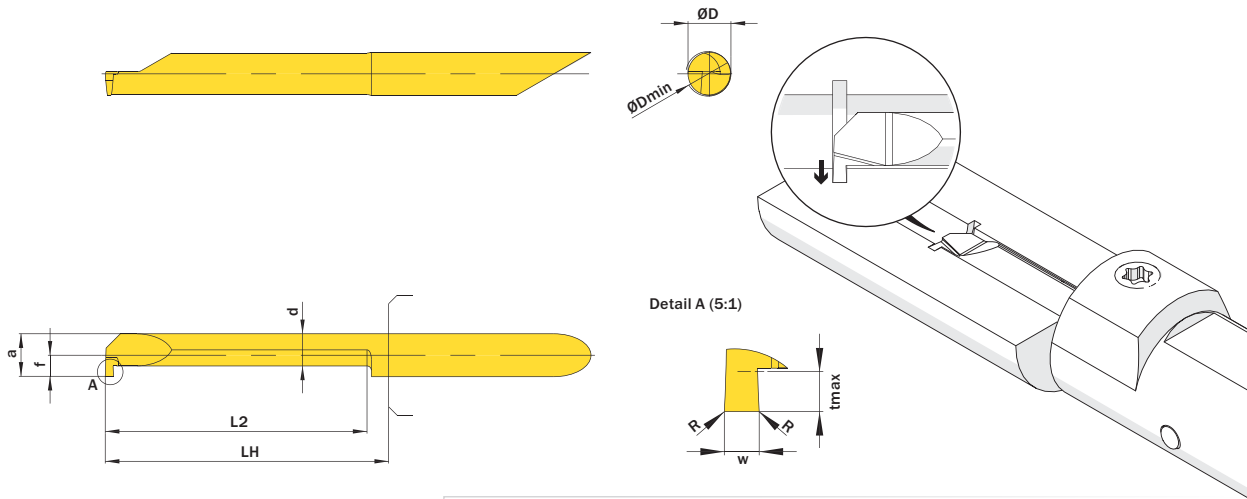

Mehr Informationen zur Kühlmittelzufuhr finden Sie auf Seite 22
Additional information about through coolant supply on page 22

ØD	w ^{+0,03}	L2	ØDmin (Min. Bohrung) ØDmin (min. bore)	Kühlmittelzufuhr Through coolant supply	Artikelnummer Part number	Webcode www.simtek.com/webcode	Unsere erste Wahl Our first choice	a	d	f	LH	R	tmax	Connectcode www.simtek.com/code
mm	mm	mm	mm				P K M N S	mm	mm	mm	mm	mm	mm	

Fortgesetzte Tabelle // Continued Table
Verwandte Werkzeuge finden Sie auch auf der vorhergehenden Seite!
Related Items can be found on the previous page as well!

▼ w = 1,5 mm														
5,0	1,5	10,2	5,2	+	A05.0150.10.52 GR/L	R AG38 L AF9C	X800 X400	4,95	3,75	2,45	13,0	-	1,0	R A05.R L A05.L
5,0	1,5	15,2	5,2	+	A05.0150.15.52 GR/L	R ANY8 L AFUK	X800 X400	4,95	3,75	2,45	18,0	-	1,0	R A05.R L A05.L
5,0	1,5	20,3	5,2	+	A05.0150.20.52 GR/L	R AH57 L AJ8D	X800 X400	4,95	3,75	2,45	23,0	-	1,0	R A05.R L A05.L
5,0	1,5	25,4	5,2	+	A05.0150.25.52 GR/L	R AAKF L AFY2	X800 X400	4,95	3,75	2,45	28,0	-	1,0	R A05.R L A05.L
5,0	1,5	30,5	5,2	+	A05.0150.30.52 GR/L	R APVS L ADUG	X800 X400	4,95	3,75	2,45	33,0	-	1,0	R A05.R L A05.L
5,0	1,5	35,6	5,2	+	A05.0150.35.52 GR/L	R AKFJ L AB89	X800 X400	4,95	3,75	2,45	38,0	-	1,0	R A05.R L A05.L
▼ w = 1,575 mm														
5,0	1,575	10,2	5,2	+	A05.0157.10.52 GR/L	R APCY L APG8	X800 X400	4,95	3,75	2,45	13,0	-	1,0	R A05.R L A05.L inch
5,0	1,575	15,2	5,2	+	A05.0157.15.52 GR/L	R AMD4 L AHMW	X800 X400	4,95	3,75	2,45	18,0	-	1,0	R A05.R L A05.L inch
5,0	1,575	20,3	5,2	+	A05.0157.20.52 GR/L	R AE6P L APUC	X800 X400	4,95	3,75	2,45	23,0	-	1,0	R A05.R L A05.L inch
5,0	1,575	25,4	5,2	+	A05.0157.25.52 GR/L	R AFY0 L AHMY	X800 X400	4,95	3,75	2,45	28,0	-	1,0	R A05.R L A05.L inch
5,0	1,575	30,5	5,2	+	A05.0157.30.52 GR/L	R AJ06 L AAFP	X800 X400	4,95	3,75	2,45	33,0	-	1,0	R A05.R L A05.L inch
▼ w = 1,981 mm														
5,0	1,981	10,2	5,2	+	A05.0198.10.52 GR/L	R AJ4G L AGND	X800 X400	4,95	3,75	2,45	13,0	-	1,0	R A05.R L A05.L inch
5,0	1,981	15,2	5,2	+	A05.0198.15.52 GR/L	R ABHH L ANBC	X800 X400	4,95	3,75	2,45	18,0	-	1,0	R A05.R L A05.L inch
5,0	1,981	20,3	5,2	+	A05.0198.20.52 GR/L	R ACFG L AEM3	X800 X400	4,95	3,75	2,45	23,0	-	1,0	R A05.R L A05.L inch
5,0	1,981	25,4	5,2	+	A05.0198.25.52 GR/L	R ABS3 L AJZV	X800 X400	4,95	3,75	2,45	28,0	-	1,0	R A05.R L A05.L inch
5,0	1,981	30,5	5,2	+	A05.0198.30.52 GR/L	R AJNV L ABNQ	X800 X400	4,95	3,75	2,45	33,0	-	1,0	R A05.R L A05.L inch
5,0	1,981	30,5	5,2	+	A05.0198.30.52.10 GR	A6FB	X800 X400	4,95	3,75	2,45	33,0	0,1	1,0	A05.R new inch

Verwandte Werkzeuge finden Sie auch auf der folgenden Seite!
Related Items can be found on the following page as well!

Fortgesetzte Tabelle
Continued Table

Bestellbeispiel // Order example: **A05.0157.20.52 GR X800** (R = Rechte Ausführung // Right hand version, X800 = Schneidstoff // Grade)