

Halbzeuge, Formstechen

Halbzeuge für komponenten- und kundenspezifische Formeinstiche.

Semi-Finished-Insert, Profiling

Semi-finished-insert for component and client specific forms.

Passende Klemmhalter auf Seite // Suitable toolholders on page
416, 417, 418

SP
Legende
423

HM
Legende

Scan QR-Code
Oder besuchen Sie // Or Visit

www.simtek.info/cp/728

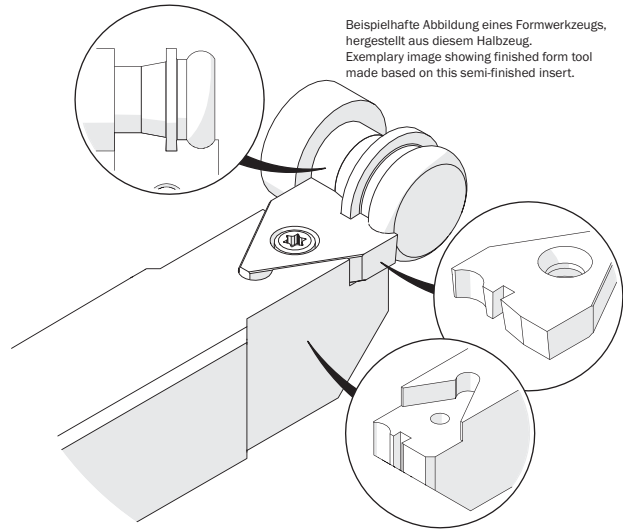
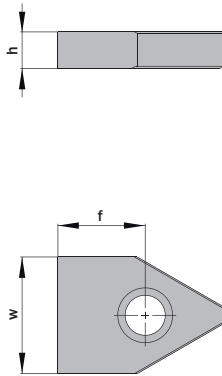

Beispielhafte Abbildung eines Formwerkzeugs, hergestellt aus diesem Halbzeug.
 Exemplary image showing finished form tool made based on this semi-finished insert.

Abbildung zeigt / Drawing shows: F12.1612.00 M

| w mm | f mm | Artikelnummer Part number | Webcode www.simtek.com/webcode | Unsere erste Wahl Our first choice | h ^{+0,05} mm | Connectcode www.simtek.com/ccode |
|----------------------|----------------|------------------------------|---|---------------------------------------|---------------------------------|---|
| | | | | P K M N S | | |
| ▼ w = 12,3 mm | | | | | | |
| 12,3 | 10,7 | F12.1210.00 M | AMWH | X800 X400 | 5,0 | TF12.A.12.10 TF12.B.12.10 |
| 12,3 | 15,2 | F12.1215.00 M | AG2E | X800 X400 | 5,0 | TF12.A.12.15 TF12.B.12.15 |
| ▼ w = 16,3 mm | | | | | | |
| 16,3 | 12,2 | F12.1612.00 M | AKWQ | X800 X400 | 5,0 | TF12.A.16.12 TF12.B.16.12 |
| 16,3 | 15,2 | F12.1615.00 M | AECD | X800 X400 | 5,0 | TF12.A.16.15 TF12.B.16.15 |
| ▼ w = 20,3 mm | | | | | | |
| 20,3 | 15,2 | F12.2015.00 M | AA30 | X800 X400 | 5,0 | TF12.A.20.15 TF12.B.20.15 |
| ▼ w = 25,3 mm | | | | | | |
| 25,3 | 15,2 | F12.2515.00 M | AGXU | X800 X400 | 5,0 | TF12.A.25.15 TF12.B.25.15 |

Bestellbeispiel // Order example: **F12.1210.00 M X800** (X800 = Schneidstoff // Grade)

simturn AX
simturn DX
simturn PX
simturn H2
simturn K2
simturn C4
simturn GX
simturn E3
simturn E12
simturn FX
simturn OA
Index