

Nutenstechen

Geeignet ab Bohrungsdurchmesser 6,2 mm.

Grooving

For use in bores as of minimum bore diameter 6,2 mm.

Schnittwerte (Start) // Cutting parameters (start)

f	Vc
0,02 mm/U	Seite/Page 429

Passende Klemmhalter auf Seite // Suitable toolholders on page

28, 31, 36, 42, 45, 50, 51, 53, 55,
56, 58, 61, 62, 64, 65, 66, 67, 68,
69

Vergleichbare Werkzeuge auf Seite // Similar tools on page

102



Legende
Legend 139

Scan QR-Code Oder besuchen Sie // Or Visit
www.simtek.info/cp/798

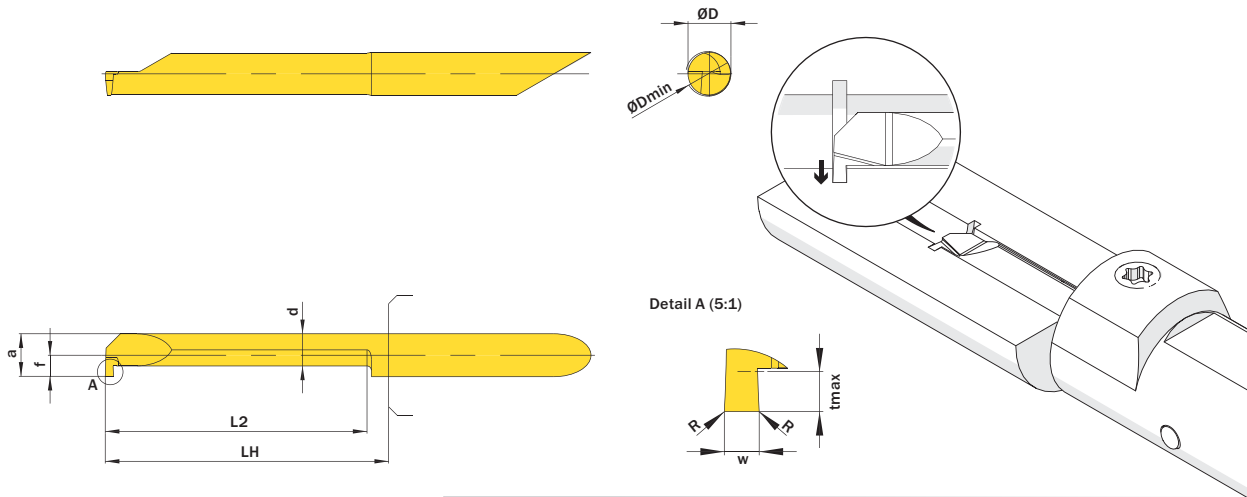

Mehr Informationen zur Kühlmittelzufuhr finden Sie auf Seite 22
Additional information about through coolant supply on page 22

ØD	w ^{+0,03}	L2	ØDmin (Min. Bohrung) ØDmin (min. bore)	Kühlmittelzufuhr Through coolant supply	Artikelnummer Part number	Webcode www.simtek.com/webcode	Unsere erste Wahl Our first choice	a	d	f	LH	R	tmax	Connectcode www.simtek.com/code
mm	mm	mm	mm				P K M N S	mm	mm	mm	mm	mm	mm	

Fortgesetzte Tabelle
Continued Table

Verwandte Werkzeuge finden Sie auch auf der vorhergehenden Seite!
Related items can be found on the previous page as well!

▼ w = 1,5 mm																				
6,0	1,5	10,2	6,2	+	A06.0150.10.62 GR/L	R	ACH4	L	ADTA	X800 X400	5,95	3,95	2,95	13,0	-	1,8	R	A06.R	L	A06.L
6,0	1,5	15,2	6,2	+	A06.0150.15.62 GR/L	R	ADPJ	L	AKTA	X800 X400	5,95	3,95	2,95	18,0	-	1,8	R	A06.R	L	A06.L
6,0	1,5	20,3	6,2	+	A06.0150.20.62 GR/L	R	AFH9	L	AF35	X800 X400	5,95	3,95	2,95	23,0	-	1,8	R	A06.R	L	A06.L
6,0	1,5	25,4	6,2	+	A06.0150.25.62 GR/L	R	AFHV	L	AJØP	X800 X400	5,95	3,95	2,95	28,0	-	1,8	R	A06.R	L	A06.L
6,0	1,5	30,5	6,2	+	A06.0150.30.62 GR/L	R	ANT7	L	AGBØ	X800 X400	5,95	3,95	2,95	33,0	-	1,8	R	A06.R	L	A06.L
6,0	1,5	35,6	6,2	+	A06.0150.35.62 GR/L	R	ACUC	L	APT7	X800 X400	5,95	3,95	2,95	38,0	-	1,8	R	A06.R	L	A06.L
▼ w = 1,575 mm																				
6,0	1,575	10,2	6,2	+	A06.0157.10.62 GR/L	R	AES5	L	AK6U	X800 X400	5,95	3,95	2,95	13,0	-	1,8	R	A06.R	L	A06.L
6,0	1,575	15,2	6,2	+	A06.0157.15.62 GR/L	R	AJAB	L	AJYH	X800 X400	5,95	3,95	2,95	18,0	-	1,8	R	A06.R	L	A06.L
6,0	1,575	20,3	6,2	+	A06.0157.20.62 GR/L	R	ADAB	L	AJBY	X800 X400	5,95	3,95	2,95	23,0	-	1,8	R	A06.R	L	A06.L
6,0	1,575	25,4	6,2	+	A06.0157.25.62 GR/L	R	AJFE	L	AAAE	X800 X400	5,95	3,95	2,95	28,0	-	1,8	R	A06.R	L	A06.L
6,0	1,575	30,5	6,2	+	A06.0157.30.62 GR/L	R	AK3J	L	AK1G	X800 X400	5,95	3,95	2,95	33,0	-	1,8	R	A06.R	L	A06.L
6,0	1,575	35,6	6,2	+	A06.0157.35.62 GR/L	R	AMBZ	L	AHSN	X800 X400	5,95	3,95	2,95	38,0	-	1,8	R	A06.R	L	A06.L
6,0	1,575	40,6	6,2	+	A06.0157.40.62 GR/L	R	AG12	L	AH5K	X800 X400	5,95	3,95	2,95	43,0	-	1,8	R	A06.R	L	A06.L

Verwandte Werkzeuge finden Sie auch auf der folgenden Seite!
Related items can be found on the following page as well!

Fortgesetzte Tabelle
Continued Table

Bestellbeispiel // Order example: A06.0150.20.62 GR X800 (R = Rechte Ausführung // Right hand version, X800 = Schneidstoff // Grade)



A06. w, 1/100 mm, 3 Stellen/Digits . L2, 1/1 mm, 2 Stellen/Digits .62. R, 1/100 mm, 3 Stellen/Digits Toleranz // Tolerance R/L
Beispielartikelnummer // Example Part number: A06.137.15.62.015 XN R oder/ or A06.137.15.62.015 XN L