

# Vorstechen und Fasen

Geeignet ab Bohrungsdurchmesser 3,7 mm.

# Pre-Part-Off and Chamfering

For use in bores as of minimum bore diameter 3,7 mm.

Schnittwerte (Start) // Cutting parameters (start)

f	Vc
0,02 mm/U	Seite/Page 429

Passende Klemmhalter auf Seite // Suitable toolholders on page

26, 27, 28, 31, 32, 33, 34, 35, 36,  
 40, 41, 42, 43, 44, 45, 50, 51, 53,  
 55, 56, 57, 58, 60, 61, 62, 63, 64,  
 65, 66, 67, 68, 69



**SP** **HM** **R** **Legende** **139**  
 Legend  
 Oder besuchen Sie // Or Visit  
[www.simtek.info/cp/779](http://www.simtek.info/cp/779)



Abbildung zeigt / Drawing shows: A05.0100.20.52 PR



Mehr Informationen zur Kühlmittelzufuhr finden Sie auf Seite 22  
 Additional information about through coolant supply on page 22

ØD	w	L2	ØDmin (Min. Bohrung) ØDmin (min. bore)	Kühlmittelzufuhr Through coolant supply	Artikelnummer Part number	Webcode www.simtek.com/webcode	Unsere erste Wahl Our first choice	a	d	f	LH	t	tmax	Connectcode www.simtek.com/code
mm	mm	mm	mm				P K M N S	mm	mm	mm	mm	mm	mm	
<b>▼ ØDmin (Min. Bohrung) // ØDmin (min. bore) = 3,7 mm</b>														
4,0	1,0	10,2	3,7	+	<b>A04.0100.10.37 PR/L</b>	R AEDE L AVEZ	X800 X400	3,45	2,45	1,7	13,0	0,2	0,7	R A04.R   A04C.R L A04.L   A04C.L
4,0	1,0	15,2	3,7	+	<b>A04.0100.15.37 PR/L</b>	R ACD1 L AVEØ	X800 X400	3,45	2,45	1,7	18,0	0,2	0,7	R A04.R   A04C.R L A04.L   A04C.L
<b>▼ ØDmin (Min. Bohrung) // ØDmin (min. bore) = 4,2 mm</b>														
4,0	1,0	20,3	4,2	+	<b>A04.0100.20.42 PR/L</b>	R AJ2W L AVE1	X800 X400	3,95	2,95	1,95	23,0	0,2	0,7	R A04C.R L A04C.L
<b>▼ ØDmin (Min. Bohrung) // ØDmin (min. bore) = 5,2 mm</b>														
5,0	1,0	15,2	5,2	+	<b>A05.0100.15.52 PR/L</b>	R AFZX L AD7M	X800 X400	4,95	3,75	2,45	18,0	0,2	0,7	R A05.R L A05.L
5,0	1,0	20,3	5,2	+	<b>A05.0100.20.52 PR/L</b>	R ADØE L ANDY	X800 X400	4,95	3,75	2,45	23,0	0,2	0,7	R A05.R L A05.L
5,0	1,0	25,4	5,2	+	<b>A05.0100.25.52 PR/L</b>	R AHXE L AHFW	X800 X400	4,95	3,75	2,45	28,0	0,2	0,7	R A05.R L A05.L
5,0	1,0	30,5	5,2	+	<b>A05.0100.30.52 PR/L</b>	R AG19 L AH2E	X800 X400	4,95	3,75	2,45	33,0	0,2	0,7	R A05.R L A05.L
<b>▼ ØDmin (Min. Bohrung) // ØDmin (min. bore) = 6,2 mm</b>														
6,0	1,0	30,5	6,2	+	<b>A06.0100.30.62 PR/L</b>	R AFNW L AU6N	X800 X400	5,95	3,95	2,95	33,0	0,2	0,7	R A06.R L A06.L
6,0	1,0	40,6	6,2	+	<b>A06.0100.40.62 PR/L</b>	R AB64 L AU6P	X800 X400	5,95	3,95	2,95	43,0	0,2	0,7	R A06.R L A06.L

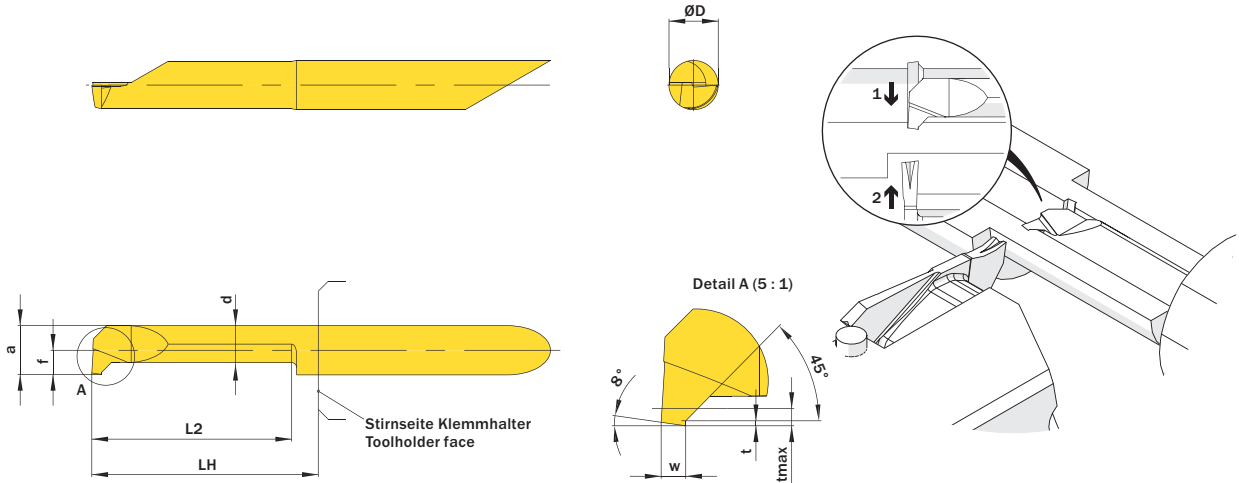
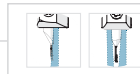
Bestellbeispiel // Order example: **A06.0100.30.62 PR X800** (R = Rechte Ausführung // Right hand version, X800 = Schneidstoff // Grade)