

Gewindedrehen, BSW/BSF Vollprofil

Herstellung des vollständigen Gewindeprofils mit erforderlicher Tiefe sowie Kopf- und Fußradien.

Threading, BSW/BSF Full Profile

For a complete thread profile with correct depth, top radius and bottom radius.

Schnittwerte (Start) // Cutting parameters (start)
Anzahl Durchgänge // Number of passes 10 - 16
Empf. Zustellungsart // Recom. infeed method Modifizierte einseitige Flankenzustellung // Modified one-sided flank infeed (Seite/Page 447)
Vc Seite/Page 442

Passende Klemmhalter auf Seite // Suitable toolholders on page
172, 173, 174, 176, 178, 180, 181

SP
HM

Legende
Legend

238

Scan QR-Code Oder besuchen Sie // Or Visit
www.simtek.info/cp/821

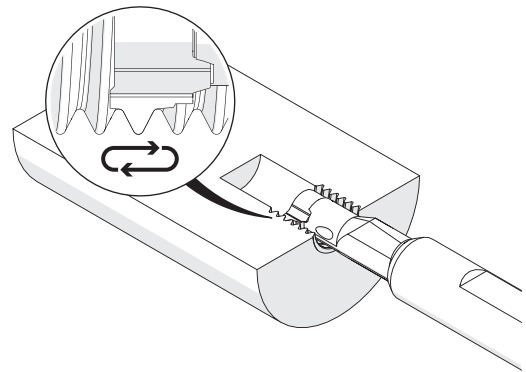
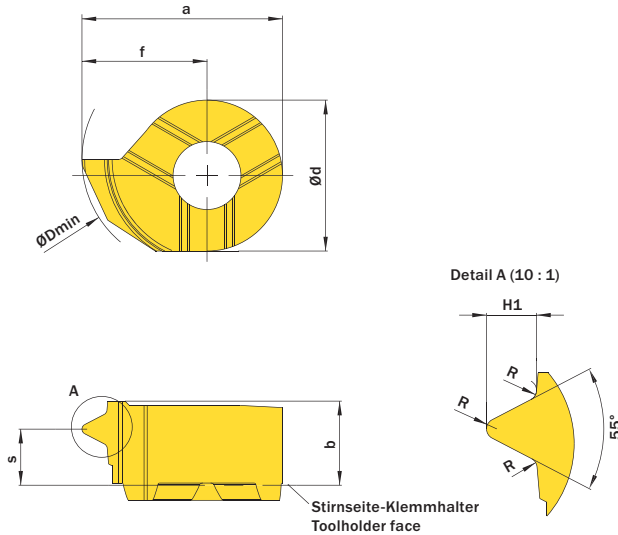

Abbildung zeigt / Drawing shows: D10.1118.14.10 M R

H1	Steigung (von) Pitch (as of)	Gang/Zoll Threads/inch	Artikelnummer Part number	Webcode www.simtek.com/webcode	Empfohlene Schneidstoffe Recommended cutting grades	a	b	Ød	ØDmin (Min. Bohrung) ØDmin (min. bore)	f	R	S	Connectcode www.simtek.com/code
▼ ØDmin (Min. Bohrung) // ØDmin (min. bore) = 10,0 mm													
0,85	1,337	19	D10.0813.19.10 MR/L	R AF1V L AD9V	X800 X400 X600 GX79 X500 X400	9,3	3,8	7,0	10,0	5,8	0,18	2,8	D10
1,16	1,814	14	D10.1118.14.10 MR/L	R APMJ L ADU8	X800 X400 X600 GX79 X500 X400	9,3	3,8	7,0	10,0	5,8	0,24	2,6	D10
1,48	2,309	11	D10.1423.11.10 MR/L	R AFYX L APUK	X800 X400 X600 GX79 X500 X400	9,3	3,8	7,0	10,0	5,8	0,31	2,3	D10
▼ ØDmin (Min. Bohrung) // ØDmin (min. bore) = 11,0 mm													
0,85	1,337	19	D11.0813.19 MR/L	R AMMN L AKQV	X800 X400 X600 GX79 X500 X400	10,7	4,3	8,0	11,0	6,7	0,18	2,7	D11
1,16	1,814	14	D11.1118.14 MR/L	R AGJS L AB2A	X800 X400 X600 GX79 X500 X400	10,7	4,3	8,0	11,0	6,7	0,24	3,0	D11
▼ ØDmin (Min. Bohrung) // ØDmin (min. bore) = 14,0 mm													
0,85	1,337	19	D14.0813.19 MR/L	R ANYF L AGT5	X800 X400 X600 GX79 X500 X400	13,5	5,4	9,0	14,0	9,0	0,18	3,8	D14
1,16	1,814	14	D14.1118.14 MR/L	R AGGU L APH5	X800 X400 X600 GX79 X500 X400	13,5	5,4	9,0	14,0	9,0	0,24	3,6	D14
▼ ØDmin (Min. Bohrung) // ØDmin (min. bore) = 16,0 mm													
1,16	1,814	14	D16.1118.14 MR/L	R AGFF L ABXY	X800 X400 X600 GX79 X500 X400	15,7	5,4	11,0	16,0	10,2	0,24	3,9	D16
1,48	2,309	11	D16.1423.11 MR/L	R AMQC L AKAB	X800 X400 X600 GX79 X500 X400	15,7	5,4	11,0	16,0	10,2	0,31	3,5	D16

Bestellbeispiel // Order example: **D10.0813.19.10 MR X800** (R = Rechte Ausführung // Right hand version, X800 = Schneidstoff // Grade)

simturn AX
simturn DX
simturn PX
simturn H2
simturn K2
simturn GX
simturn E3
simturn E12
simturn FX
simturn Decolletage
simturn OA
Index