

## Einstecken und Profildrehen

CNC-Konturdrehen mit runder, geschliffener Spanfläche.

## Grooving and Profiling

CNC profiling. Ground, round geometry.

Schnittwerte (Start) // Cutting parameters (start)

f (außen//ext.) <b>0,05 mm/U</b>	f (innen//int.) <b>0,04 mm/U</b>	Vc <b>Seite/Page 429</b>
-------------------------------------	-------------------------------------	-----------------------------

Passende Klemmhalter auf Seite // Suitable toolholders on page

**295, 296, 297, 298, 299, 300, 301, 302, 303**



**SP** Legende  
**HM** Legend

**315**

Scan  
 QR-Code

Oder besuchen Sie // Or Visit  
[www.simtek.info/cp/519](http://www.simtek.info/cp/519)

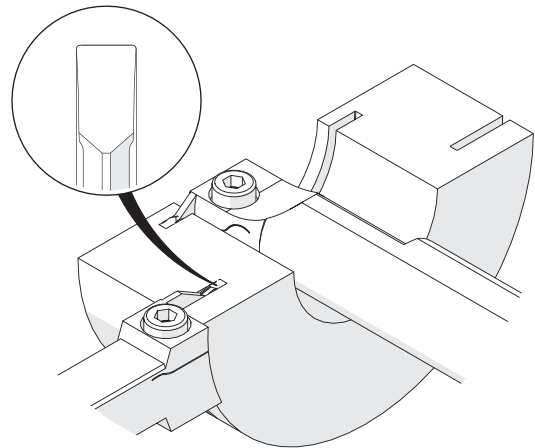
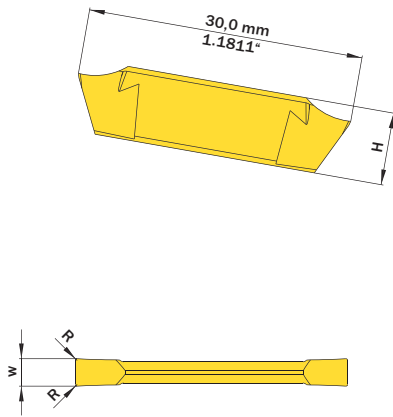

Abbildung zeigt / Drawing shows: G29.0300.10 S

$w^{+0,05}$ mm	Artikelnummer Part number	Webcode <a href="http://www.simtek.com/webcode">www.simtek.com/webcode</a>	Unsere erste Wahl Our first choice	H mm	R mm	Connectcode <a href="http://www.simtek.com/code">www.simtek.com/code</a>
2,0	<b>G29.0200.10 S</b>	AH87	<b>P</b> <b>K</b> <b>M</b> <b>N</b> <b>S</b> X800 X400	7,9	0,2	G29.02
2,5	<b>G29.0250.10 S</b>	AG6S	X800 X400	7,9	0,2	G29.02
3,0	<b>G29.0300.10 S</b>	ACA7	X800 X400	7,9	0,2	G29.03
4,0	<b>G29.0400.10 S</b>	AES9	X800 X400	7,9	0,2	G29.03   G29.04
5,0	<b>G29.0500.10 S</b>	AFY3	X800 X400	7,9	0,2	<b>G29.04</b>
6,0	<b>G29.0600.10 S</b>	AJKN	X800 X400	7,5	0,2	G29.06

Bestellbeispiel // Order example: **G29.0300.10 S X800** (X800 = Schneidstoff // Grade)