

Axialstechen

Für die Herstellung von Axialnuten.
 Bitte beachten Sie die Freiwinkel.

Face Grooving

For face grooves in different widths.
 Available with different clearance angles.

Schnittwerte (Start) // Cutting parameters (start)

f (außen//ext.) 0,04 mm/U	Vc Seite/Page 429
-------------------------------------	-----------------------------

Passende Klemmhalter auf Seite // Suitable toolholders on page
323, 324, 325, 326, 327, 328



Legende
 Legend **354**

Scan
 QR-Code

Oder besuchen Sie // Or Visit
www.simtek.info/cp/327

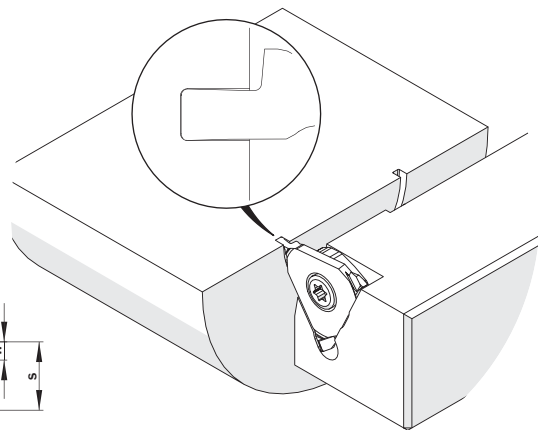
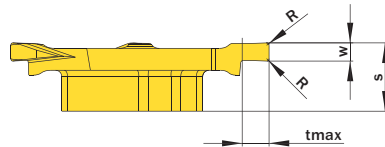
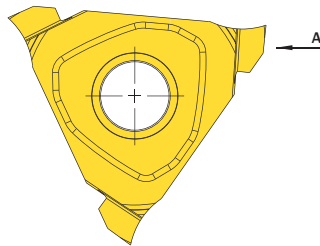
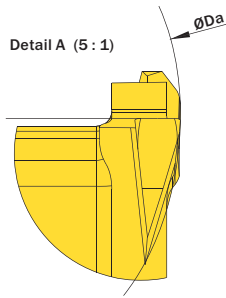

Abbildung zeigt / Drawing shows: TE3.R150.020 AG R

$w \pm 0,02$	R	Artikelnummer Part number	Webcode www.simtek.com/webcode	Unsere erste Wahl Our first choice	$\varnothing Da$	S	tmax	Connectcode www.simtek.com/code
mm	mm			P K M N S	mm	mm	mm	
1,5	0,2	TE3.R150.020 AG R	AF5U	X800 X400	30,0	5,6	2,0	TE3.R.5.3
2,0	0,2	TE3.R200.020 AG R	AFVU	X800 X400	30,0	5,6	3,0	TE3.R.5.3
3,0	0,2	TE3.R300.020 AG R	ANNM	X800 X400	30,0	5,6	3,0	TE3.R.5.3

Bestellbeispiel // Order example: **TE3.R300.020 AG R X800** (R = Rechte Ausführung // Right hand version, X800 = Schneidstoff // Grade)