

Axialstechen in Bohrungen

Volle Stechtiefe ab Bohrungsdurchmesser 16,0 mm.
Reduzierte Stechtiefe bereits ab Bohrungsdurchmesser 10,0 mm.

Face Grooving in Bores

Full cutting depth as of minimum bore diameter 16,0 mm.
Reduced cutting depth possible as of minimum bore diameter 10,0 mm.

Schnittwerte (Start) // Cutting parameters (start)

f	Vc
0,02 mm/U	Seite/Page 429

Passende Klemmhalter auf Seite // Suitable toolholders on page
30, 38, 47, 52, 54, 59, 67, 68, 69



SP **HM** **R** Legende Legend **139**
Scan QR-Code Oder besuchen Sie // Or Visit www.simtek.info/cp/761

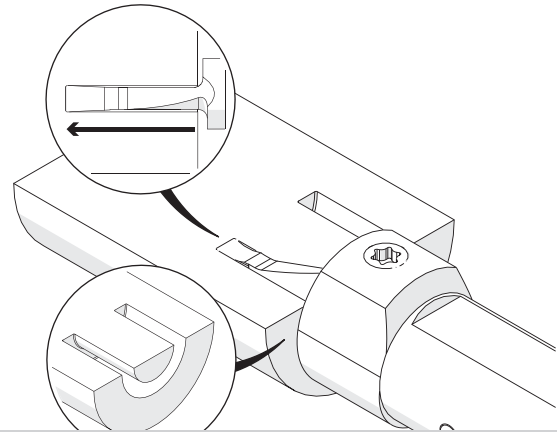
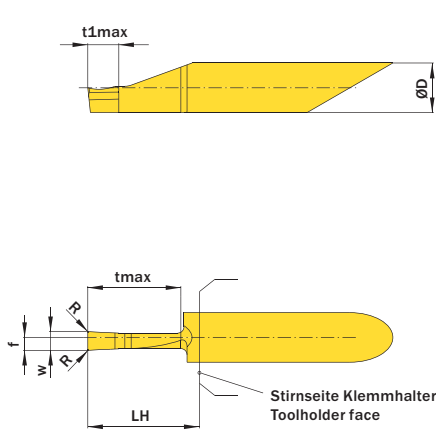

Stechtiefe „tmax“ gilt ab Bohrungsdurchmesser gem. Angabe in Spalte „Ab Bohrungsdurchmesser“
Stechtiefe „t1max“ gilt ab Bohrungsdurchmesser gem. Angabe in Spalte „D1min“
Cutting depth „tmax“ is possible as of bore diameter as stated in column „As of bore diameter“
Cutting depth „t1max“ is possible as of bore diameter as stated in column „D1min“

Abbildung zeigt / Drawing shows: A08.0300.15.00 AG R



Mehr Informationen zur Kühlmittelzufuhr finden Sie auf Seite 22
Additional information about through coolant supply on page 22

ØD	w ^{+0,05}	tmax	Kühlmittelzufuhr Through coolant supply	Artikelnummer Part number	Webcode www.simtek.com/webcode	Unsere erste Wahl Our first choice	ØDmin (Min. Bohrung) ØDmin (min. bore)	t1max	D1min	f	LH	R	Connectcode www.simtek.com/code	
mm	mm	mm				P K M N S	mm	mm	mm	mm	mm	mm		
▼ w = 2,0 mm														
8,0	2,0	10,0	+	A08.0200.10.00 AG R/L	R AV5V	L AV5U	X800 X400	16,0	-	-	1,51	15,0	0,2	A08
8,0	2,0	15,0	+	A08.0200.15.00 AG R/L	R AKK7	L AHEV	X800 X400	16,0	-	-	1,51	20,0	0,2	A08
▼ w = 2,5 mm														
8,0	2,5	10,0	+	A08.0250.10.00 AG R/L	R ABJN	L AMFN	X800 X400	16,0	3,0	10,0	1,8	15,0	0,2	A08
8,0	2,5	15,0	+	A08.0250.15.00 AG R/L	R AV5Z	L AV5Y	X800 X400	16,0	3,0	10,0	1,8	20,0	0,2	A08
▼ w = 3,0 mm														
8,0	3,0	10,0	+	A08.0300.10.00 AG R/L	R ANH7	L AGHC	X800 X400	16,0	3,0	10,0	2,07	15,0	0,2	A08
8,0	3,0	15,0	+	A08.0300.15.00 AG R/L	R APG2	L AF4K	X800 X400	16,0	3,0	10,0	2,07	20,0	0,2	A08
▼ w = 4,0 mm														
8,0	4,0	10,0	+	A08.0400.10.00 AG R/L	R AFJ9	L AFV6	X800 X400	16,0	3,0	10,0	2,49	15,0	0,2	A08
8,0	4,0	15,0	+	A08.0400.15.00 AG R/L	R AMQ5	L AEWV	X800 X400	16,0	3,0	10,0	2,49	20,0	0,2	A08

Bestellbeispiel // Order example: **A08.0200.10.00 AG R X800** (R = Rechte Ausführung // Right hand version, X800 = Schneidstoff // Grade)