

Einstecken und Profildrehen

CNC-Konturdrehen mit gesinterter Spanformgeometrie für kontrollierte Spanbildung.

Grooving and Profiling

CNC profiling. Sintered geometry for improved chip control.

Schnittwerte (Start) // Cutting parameters (start)

f (außen//ext.) 0,12 mm/U	f (innen//int.) 0,09 mm/U	Vc Seite/Page 429
-------------------------------------	-------------------------------------	-----------------------------

Passende Klemmhalter auf Seite // Suitable toolholders on page

295, 296, 297, 298, 299, 300, 301, 302, 303



SP Legende
HM Legend

315

Scan QR-Code

Oder besuchen Sie // Or Visit
www.simtek.info/cp/521

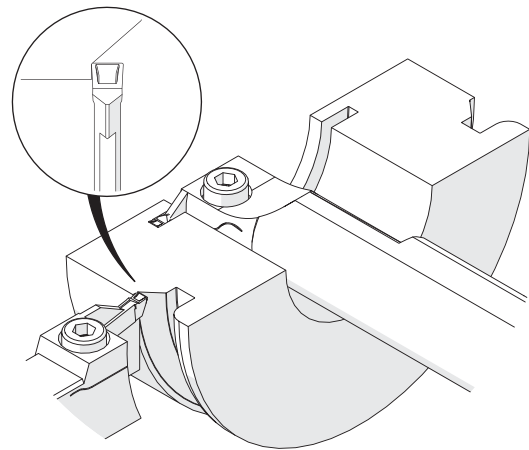
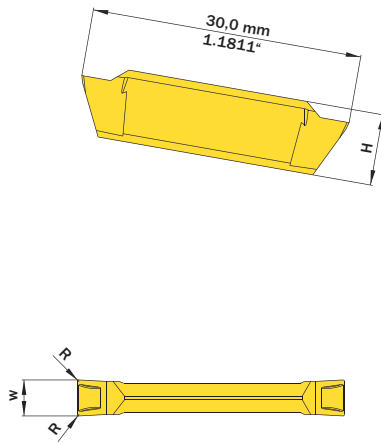

Abbildung zeigt / Drawing shows: G29.0400.32 S

w ^{+0,05} mm	R mm	Artikelnummer Part number	Webcode www.simtek.com/webcode	Unsere erste Wahl Our first choice P K M N S	H mm	Connectcode www.simtek.com/code
2,0	0,2	G29.0200.32 S	ABNM	X800 X400	7,9	G29.02
2,5	0,2	G29.0250.32 S	AHMB	X800 X400	7,9	G29.02
3,0	0,2	G29.0300.32 S	AFPT	X800 X400	7,9	G29.03
3,0	0,4	G29.0300.34 S	AN8A	X800 X400	7,9	G29.03
3,175	0,2	G29.0318.32 S	A6DD	X800 X400	7,9	G29.03
3,175	0,4	G29.0318.34 S	A6DF	X800 X400	7,9	G29.03
4,0	0,2	G29.0400.32 S	AJK1	X800 X400	7,9	G29.03 G29.04
4,0	0,4	G29.0400.34 S	AAE0	X800 X400	7,9	G29.03 G29.04
5,0	0,4	G29.0500.34 S	AN6E	X800 X400	7,9	G29.04
6,0	0,4	G29.0600.34 S	AE8G	X800 X400	7,5	G29.06
6,0	0,8	G29.0600.38 S	ANYA	X800 X400	7,5	G29.06
6,35	0,2	G29.0635.32 S	A6DV	X800 X400	7,5	G29.06
6,35	0,4	G29.0635.34 S	A6DT	X800 X400	7,5	G29.06

Bestellbeispiel // Order example: **G29.0300.34 S X800** (X800 = Schneidstoff // Grade)