

# Nutenstechen

Für allgemeines Nutenstechen und für Sicherungsringnuten.  
Geeignet ab Bohrungsdurchmesser 8,0 mm.

# Grooving

For general grooving as well as for circlip ring grooving.  
For use in bores as of minimum bore diameter 8,0 mm.

Schnittwerte (Start) // Cutting parameters (start)	
f <b>0,02 mm/U</b>	Vc <b>Seite/Page 429</b>

Passende Klemmhalter auf Seite // Suitable toolholders on page <b>154, 163</b>
---

Vergleichbare Werkzeuge auf Seite // Similar tools on page <b>175</b>
--

SP

HM

R

Legende  
Legend **213**

Scan  
QR-Code

Oder besuchen Sie // Or Visit  
[www.simtek.info/cp/829](http://www.simtek.info/cp/829)



Abbildung zeigt / Drawing shows: D08.0110.00 G R

w <sup>+0,03</sup>	Nutenbreite Nominal width of groove	ØDmin (Min. Bohrung) ØDmin (min. bore)	Artikelnummer Part number	Webcode www.simtek.com/webcode	Unsere erste Wahl Our first choice	a	Ød	f	R	S	tmax	Connectcode www.simtek.com/code
mm	mm	mm			P K M N S	mm	mm	mm	mm	mm	mm	

Fortgesetzte Tabelle Continued Table Verwandte Werkzeuge finden Sie auch auf der vorhergehenden Seite!  
Related items can be found on the previous page as well!

0,73	0,7	8,0	<b>D08.0070.00 ZR/L</b>	R AB9U L ADBZ X800 X400	7,8	6,0	4,8	-	3,3	1,0	D08
0,787	-	8,0	<b>D08.0078.00 GR/L</b>	R ANEN L AH0A X800 X400	7,8	6,0	4,8	-	3,3	1,0	D08 <span style="float: right;">inch</span>
0,83	0,8	8,0	<b>D08.0080.00 ZR/L</b>	R AKJ6 L AMGG X800 X400	7,8	6,0	4,8	-	3,3	1,0	D08
0,93	0,9	8,0	<b>D08.0090.00 ZR/L</b>	R AN56 L AMYN X800 X400	7,8	6,0	4,8	-	3,3	1,0	D08
1,0	-	8,0	<b>D08.0100.00 GR/L</b>	R AKUA L AGCE X800 X400	7,8	6,0	4,8	-	3,3	1,0	D08
1,2	1,1	8,0	<b>D08.0110.00 GR/L</b>	R ABPM L ANT9 X800 X400	7,8	6,0	4,8	-	3,3	1,0	D08
1,4	1,3	8,0	<b>D08.0130.00 GR/L</b>	R AMN4 L AG33 X800 X400	7,8	6,0	4,8	-	3,3	1,0	D08
1,5	-	8,0	<b>D08.0150.00 GR/L</b>	R AK83 L AFKC X800 X400	7,8	6,0	4,8	-	3,3	1,0	D08
1,575	-	8,0	<b>D08.0157.00 GR/L</b>	R AKYG L AHA1 X800 X400	7,8	6,0	4,8	-	3,3	1,0	D08 <span style="float: right;">inch</span>
1,7	1,6	8,0	<b>D08.0160.00 GR/L</b>	R ACV2 L AGGD X800 X400	7,8	6,0	4,8	-	3,3	1,0	D08
1,981	-	8,0	<b>D08.0198.00 GR/L</b>	R AE0H L AK8B X800 X400	7,8	6,0	4,8	-	3,3	1,0	D08 <span style="float: right;">new inch</span>
2,0	-	8,0	<b>D08.0200.00 GR/L</b>	R AJB6 L ANSM X800 X400	7,8	6,0	4,8	-	3,3	1,0	D08

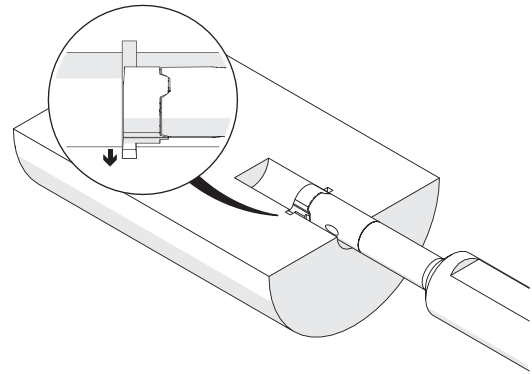
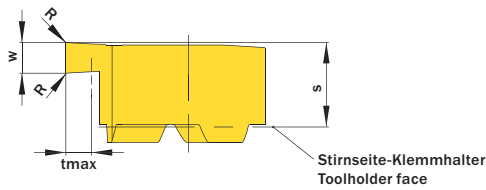
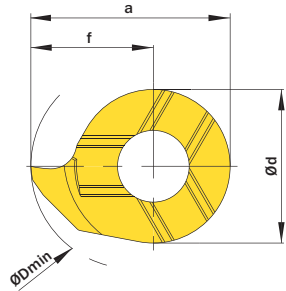
Verwandte Werkzeuge finden Sie auch auf der folgenden Seite!  
Related items can be found on the following page as well!

Fortgesetzte Tabelle  
Continued Table ▶

Bestellbeispiel // Order example: **D08.0150.00 GR X800** (R = Rechte Ausführung // Right hand version, X800 = Schneidstoff // Grade)



D08. w, 1/100 mm, 4 Stellen/Digits . R, 1/100 mm, 3 Stellen/Digits Toleranz // Tolerance R/L  
Beispielartikelnummer // Example Part number: **D08.0156.015 XN R** oder//or **D08.0156.015 XN L**