

Nutenstechen

Für allgemeines Nutenstechen und für Sicherungsringnuten.
Geeignet ab Bohrungsdurchmesser 11,0 mm.

Grooving

For general grooving as well as for circlip ring grooving.
For use in bores as of minimum bore diameter 11,0 mm.

Schnittwerte (Start) // Cutting parameters (start)	
f 0,02 mm/U	Vc Seite/Page 429

Passende Klemmhalter auf Seite // Suitable toolholders on page 157, 163

Vergleichbare Werkzeuge auf Seite // Similar tools on page 175
--

SP

HM

R

Legende
Legend **213**

Scan
QR-Code

Oder besuchen Sie // Or Visit
www.simtek.info/cp/840

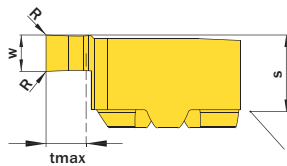
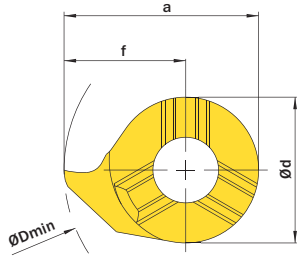

Stirnseite Klemmhalter
Toolholder face



Abbildung zeigt / Drawing shows: D11.0200.00 G R

w ^{+0,03}	Nutnenbreite Nominal width of groove	ØDmin (Min. Bohrung) ØDmin (min. bore)	Artikelnummer Part number	Webcode www.simtek.com/webcode	Unsere erste Wahl Our first choice	a	Ød	f	R	S	tmax	Connectcode www.simtek.com/code
mm	mm	mm			P K M N S	mm	mm	mm	mm	mm	mm	

Fortgesetzte Tabelle // Continued Table
Verwandte Werkzeuge finden Sie auch auf der vorhergehenden Seite!
Related items can be found on the previous page as well!

0,73	0,7	11,0	D11.0070.00 ZR/L	R AP1P L APPC X800 X400	10,7	8,0	6,7	-	4,2	1,2	D11	
0,787	-	11,0	D11.0078.00 ZR/L	R AMV4 L AJGV X800 X400	10,7	8,0	6,7	-	4,2	1,3	D11	inch
0,83	0,8	11,0	D11.0080.00 ZR/L	R AJWD L AAC9 X800 X400	10,7	8,0	6,7	-	4,2	1,3	D11	
0,93	0,9	11,0	D11.0090.00 ZR/L	R AJX5 L AFEU X800 X400	10,7	8,0	6,7	-	4,2	1,5	D11	
1,0	-	11,0	D11.0100.00 GR/L	R AF27 L AA5C X800 X400	10,7	8,0	6,7	-	4,2	2,3	D11	
1,2	1,1	11,0	D11.0110.00 GR/L	R AC49 L APP0 X800 X400	10,7	8,0	6,7	-	4,2	2,3	D11	
1,4	1,3	11,0	D11.0130.00 GR/L	R ABF3 L ABS9 X800 X400	10,7	8,0	6,7	-	4,2	2,3	D11	
1,5	-	11,0	D11.0150.00 GR/L	R ADEV L AMGD X800 X400	10,7	8,0	6,7	-	4,2	2,3	D11	
1,575	-	11,0	D11.0157.00 GR/L	R AEAT L APWW X800 X400	10,7	8,0	6,7	-	4,2	2,3	D11	inch
1,7	1,6	11,0	D11.0160.00 GR/L	R AK4Q L AJUG X800 X400	10,7	8,0	6,7	-	4,2	2,3	D11	
2,0	-	11,0	D11.0200.00 GR/L	R AKEC L AP30 X800 X400	10,7	8,0	6,7	-	4,2	2,3	D11	
2,388	-	11,0	D11.0238.00 GR/L	R ANH9 L AHA0 X800 X400	10,7	8,0	6,7	-	4,2	2,3	D11	inch
2,5	-	11,0	D11.0250.00 GR/L	R AB6U L AM90 X800 X400	10,7	8,0	6,7	-	4,2	2,3	D11	
3,0	-	11,0	D11.0300.00 GR/L	R AP3N L AAAF X800 X400	10,7	8,0	6,7	-	4,2	2,3	D11	
3,175	-	11,0	D11.0318.00 GR/L	R AKB5 L AF8V X800 X400	10,7	8,0	6,7	-	4,2	2,3	D11	inch

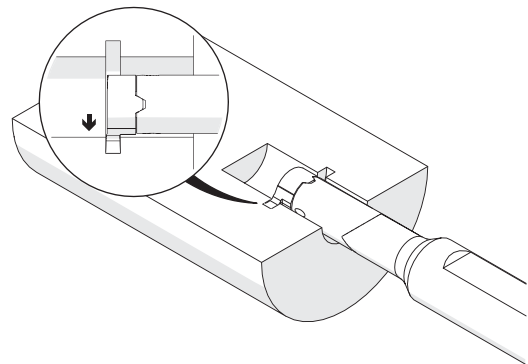
Verwandte Werkzeuge finden Sie auch auf der folgenden Seite!
Related items can be found on the following page as well!

Fortgesetzte Tabelle
Continued Table

Bestellbeispiel // Order example: **D11.0110.00 GR X800** (R = Rechte Ausführung // Right hand version, X800 = Schneidstoff // Grade)



D11. w. 1./100 mm, 4 Stellen/Digits | R. 1./100 mm, 3 Stellen/Digits | Toleranz // Tolerance R/L

Beispielartikelnummer // Example Part number: **D11.0156.015 XNR** oder/for **D11.0156.015 XNL**