

Nutenstechen

Geeignet ab Bohrungsdurchmesser 7,2 mm.

Grooving

For use in bores as of minimum bore diameter 7,2 mm.

Schnittwerte (Start) // Cutting parameters (start)

f	Vc
0,02 mm/U	Seite/Page 429

Passende Klemmhalter auf Seite // Suitable toolholders on page
29, 31, 37, 42, 46, 52, 54, 56, 58,
61, 64, 65, 66, 67, 68, 69

Vergleichbare Werkzeuge auf Seite // Similar tools on page
102



Legende
Legend 139

Scan QR-Code Oder besuchen Sie // Or Visit
www.simtek.info/cp/802

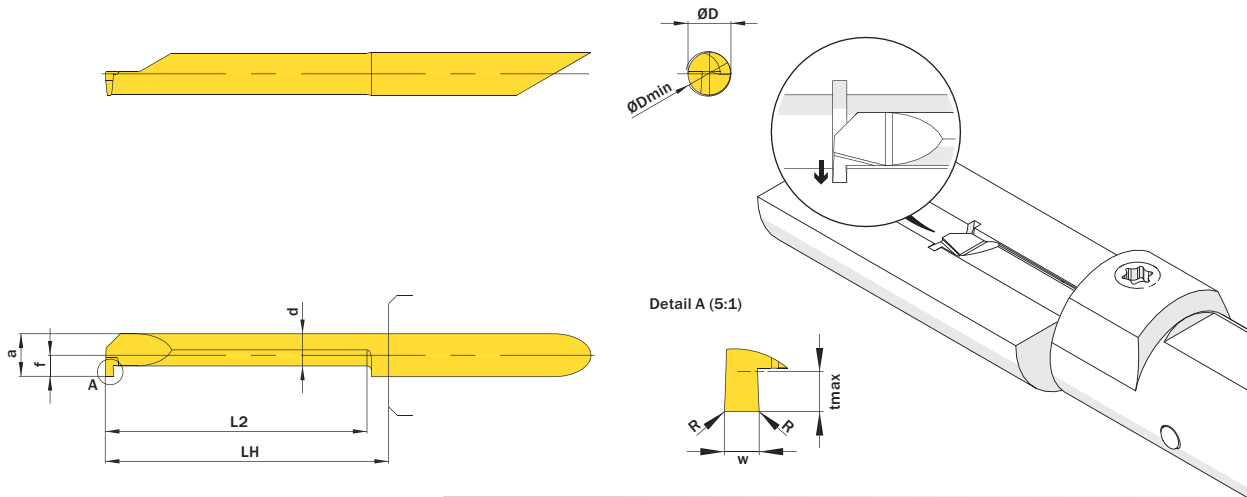

Mehr Informationen zur Kühlmittelzufuhr finden Sie auf Seite 22
Additional information about through coolant supply on page 22

ØD	w ^{+0,03}	L2	ØDmin (Min. Bohrung) ØDmin (min. bore)	Kühlmittelzufuhr Through coolant supply	Artikelnummer Part number	Webcode www.simtek.com/webcode	Unsere erste Wahl Our first choice	a	d	f	LH	R	tmax	Connectcode www.simtek.com/code
mm	mm	mm	mm				P K M N S	mm	mm	mm	mm	mm	mm	

Fortgesetzte Tabelle
Continued Table

Verwandte Werkzeuge finden Sie auch auf der vorhergehenden Seite!
Related items can be found on the previous page as well!

▼ w = 1,981 mm															
7,0	1,981	10,2	7,2	+	A07.0198.10.72 GR/L	R AHMK L APXC	X800 X400	6,95	4,25	3,45	13,0	-	2,5	R A07.R L A07.L	inch
7,0	1,981	15,2	7,2	+	A07.0198.15.72 GR/L	R AENX L AM33	X800 X400	6,95	4,25	3,45	18,0	-	2,5	R A07.R L A07.L	inch
7,0	1,981	20,3	7,2	+	A07.0198.20.72 GR/L	R AEZW L AH9Z	X800 X400	6,95	4,25	3,45	23,0	-	2,5	R A07.R L A07.L	inch
7,0	1,981	25,4	7,2	+	A07.0198.25.72 GR/L	R AB5B L AHE4	X800 X400	6,95	4,25	3,45	28,0	-	2,5	R A07.R L A07.L	inch
7,0	1,981	30,5	7,2	+	A07.0198.30.72 GR/L	R AJQG L AHPP	X800 X400	6,95	4,25	3,45	33,0	-	2,5	R A07.R L A07.L	inch
7,0	1,981	35,6	7,2	+	A07.0198.35.72 GR/L	R AFCM L AF31	X800 X400	6,95	4,25	3,45	38,0	-	2,5	R A07.R L A07.L	inch
▼ w = 2,0 mm															
7,0	2,0	10,2	7,2	+	A07.0200.10.72 GR/L	R AVF2 L AFA9	X800 X400	6,95	4,25	3,45	13,0	-	2,5	R A07.R L A07.L	
7,0	2,0	15,2	7,2	+	A07.0200.15.72 GR/L	R AEJD L AJMK	X800 X400	6,95	4,25	3,45	18,0	-	2,5	R A07.R L A07.L	
7,0	2,0	20,3	7,2	+	A07.0200.20.72 GR/L	R AAVP L ADHT	X800 X400	6,95	4,25	3,45	23,0	-	2,5	R A07.R L A07.L	
7,0	2,0	25,4	7,2	+	A07.0200.25.72 GR/L	R AGDY L AKJ0	X800 X400	6,95	4,25	3,45	28,0	-	2,5	R A07.R L A07.L	
7,0	2,0	30,5	7,2	+	A07.0200.30.72 GR/L	R AHQQ L APXY	X800 X400	6,95	4,25	3,45	33,0	-	2,5	R A07.R L A07.L	
7,0	2,0	35,6	7,2	+	A07.0200.35.72 GR/L	R AJNM L APD1	X800 X400	6,95	4,25	3,45	38,0	-	2,5	R A07.R L A07.L	

Bestellbeispiel // Order example: **A07.0200.20.72 GR X800** (R = Rechte Ausführung // Right hand version, X800 = Schneidstoff // Grade)



A07. w, 1/100 mm, 3 Stellen/Digits . L2, 1/1 mm, 2 Stellen/Digits .72. R, 1/100 mm, 3 Stellen/Digits Toleranz // Tolerance R/L
Beispielartikelnummer // Example Part number: **A07.137.15.72.015 XN R** oder // **A07.137.15.72.015 XN L**