

Allgemeines Nutfräsen

Nutfräsen gerader Nutformen.
Geeignet ab Bohrungsdurchmesser 22,0 mm.

General Groove Milling

General groove milling.
For use in bores as of minimum bore diameter 22,0 mm.

Schnittwerte (Start) // Cutting parameters (start)

fzm 0,04 mm	hmax 0,05 mm	Vc Seite/Page 638
-----------------------	------------------------	-----------------------------

Passende Klemmhalter auf Seite // Suitable toolholders on page
556, 557, 558, 559, 560, 561, 562, 563, 564

Vergleichbare Werkzeuge auf Seite // Similar tools on page
461

Bitte Hinweise im Anhang beachten // Please read add. notes
ALL (Seite/Page 645), H01 (Seite/Page 646)



SP Legende
HM Legend

650

Scan QR-Code

Oder besuchen Sie // Or Visit
www.simtek.info/cp/373

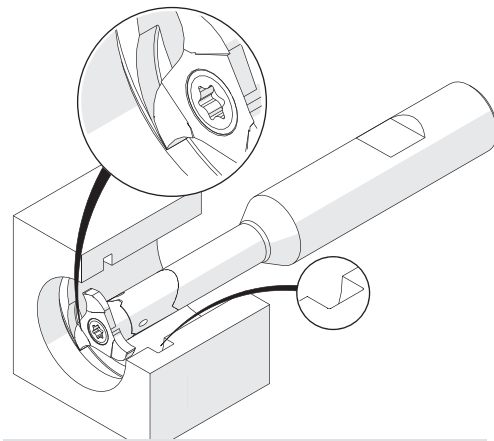
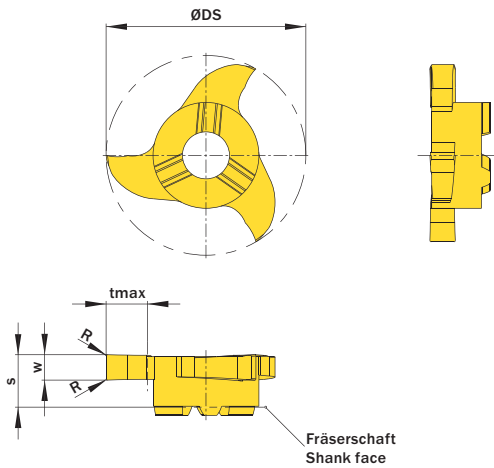

Illustration zeigt beispielhafte Anwendungsmöglichkeit mit ähnlichem Werkzeug.
Image shows exemplary application possibility with similar tool.

Abbildung zeigt / Drawing shows: V22.0250.02 G

w ^{+0,02} mm	R mm	ØDmin (Min. Bohrung) ØDmin (min. bore) mm	Artikelnummer Part number	Webcode www.simtek.com/webcode	Unsere erste Wahl Our first choice		tmax mm	S mm	ØDS mm	Anzahl Schneiden Number of cutting edges	Connectcode www.simtek.com/code
					P	M					
1,0	0,1	22,0	V22.0100.01 G	AEQM	X800	G142	4,5	5,7	21,7	3	VD12.0
1,5	0,2	22,0	V22.0150.02 G	AHH9	X800	G142	4,5	5,7	21,7	3	VD12.0
1,575	0,2	22,0	V22.0157.02 G	ANQX	X800	G142	4,5	5,7	21,7	3	VD12.0
2,0	0,2	22,0	V22.0200.02 G	ADNU	X800	G142	4,5	5,7	21,7	3	VD12.0
2,388	0,2	22,0	V22.0239.02 G	AHMN	X800	G142	4,5	5,7	21,7	3	VD12.0
2,5	0,2	22,0	V22.0250.02 G	AKKF	X800	G142	4,5	5,7	21,7	3	VD12.0
3,0	0,2	22,0	V22.0300.02 G	ABXX	X800	G142	4,5	5,7	21,7	3	VD12.0
3,175	0,2	22,0	V22.0318.02 G	AK1S	X800	G142	4,5	5,7	21,7	3	VD12.0
3,175	0,4	22,0	V22.0318.04 G	AB1P	X800	G142	4,5	5,7	21,7	3	VD12.0
3,5	0,2	22,0	V22.0350.02 G	AM6N	X800	G142	4,5	5,7	21,7	3	VD12.0
3,556	0,2	22,0	V22.0356.02 G	AD9Ø	X800	G142	4,5	5,7	21,7	3	VD12.0
4,0	0,2	22,0	V22.0400.02 G	AF5N	X800	G142	4,5	5,7	21,7	3	VD12.0
4,0	0,4	22,0	V22.0400.04 G	AGMH	X800	G142	4,5	5,7	21,7	3	VD12.0
4,369	0,2	22,0	V22.0437.02 G	AHBP	X800	G142	4,5	5,7	21,7	3	VD12.0
4,369	0,4	22,0	V22.0437.04 G	AEPH	X800	G142	4,5	5,7	21,7	3	VD12.0
4,75	0,2	22,0	V22.0475.02 G	ADF7	X800	G142	4,5	5,7	21,7	3	VD12.0
5,0	0,2	22,0	V22.0500.02 G	AZCE	X800	G142	4,5	5,7	21,7	3	VD12.0
6,35	0,2	22,0	V22.0635.02 G	A1JU	X800	G142	4,5	9,3	21,7	3	VD12.0

Bestellbeispiel // Order example: **V22.0300.02 G X800** (X800 = Schneidstoff // Grade)



V22. **w, 1/100 mm, 4 Stellen/Digits** . **R, 1/100 mm, 3 Stellen/Digits** Toleranz // Tolerance
Beispielartikelnummer // Example Part number: **V22.0179.030 XG**