

Nutenstechen

Geeignet ab Bohrungsdurchmesser 2,0 mm.

Grooving

For use in bores as of minimum bore diameter 2,0 mm.

Schnittwerte (Start) // Cutting parameters (start)

f	Vc
0,02 mm/U	Seite/Page 429

Passende Klemmhalter auf Seite // Suitable toolholders on page

26, 31, 32, 33, 34, 40, 41, 43, 50,
51, 53, 55, 56, 57, 60, 62, 63, 65,
66, 67, 68, 69

Vergleichbare Werkzeuge auf Seite // Similar tools on page
102



SP
HM
R

Legende
Legend 139

Scan QR-Code Oder besuchen Sie // Or Visit
www.simtek.info/cp/777

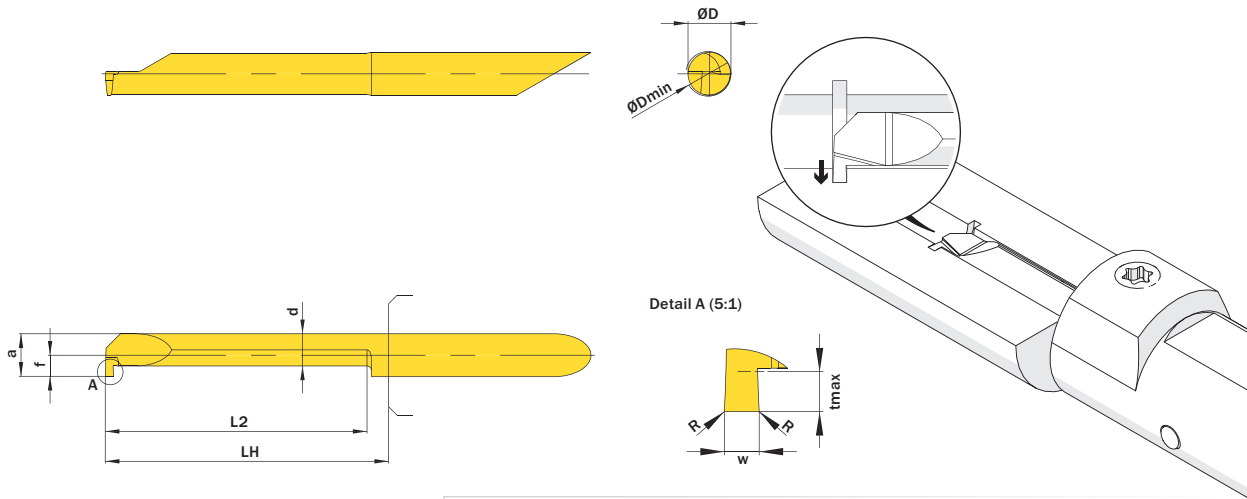

Mehr Informationen zur Kühlmittelzufuhr finden Sie auf Seite 22
Additional information about through coolant supply on page 22

ØD	w ^{+0,03}	L2	ØDmin (Min. Bohrung) ØDmin (min. bore)	Kühlmittelzufuhr Through coolant supply	Artikelnummer Part number	Webcode www.simtek.com/webcode	Unsere erste Wahl Our first choice	a	d	f	LH	R	tmax	Connectcode www.simtek.com/code
mm	mm	mm	mm				P K M N S	mm	mm	mm	mm	mm	mm	
▼ ØDmin (Min. Bohrung) // ØDmin (min. bore) = 2,0 mm														
4,0	0,5	6,1	2,0	●	A04.0050.06.20 GR/L	R AFUW L AM47	X800 X400	1,75	1,15	0,85	13,0	-	0,4	R A04.R L A04.L
4,0	0,5	6,1	2,0	+	A04.C050.06.20 GR/L	R ABQ4 L AN4H	X800 X400	1,75	1,15	1,95	13,0	-	0,4	R A04C.R L A04C.L
4,0	0,5	9,1	2,0	●	A04.0050.09.20 GR/L	R ACJY L AMSE	X800 X400	1,75	1,15	0,85	13,0	-	0,4	R A04.R L A04.L
4,0	0,5	9,1	2,0	+	A04.C050.09.20 GR/L	R AG6V L AGUA	X800 X400	1,75	1,15	1,95	13,0	-	0,4	R A04C.R L A04C.L
4,0	0,5	12,2	2,0	●	A04.0050.12.20 GR/L	R AKDC L AF5Z	X800 X400	1,75	1,15	0,85	18,0	-	0,4	R A04.R L A04.L
4,0	0,5	12,2	2,0	+	A04.C050.12.20 GR/L	R AJZ3 L ACVU	X800 X400	1,75	1,15	1,95	18,0	-	0,4	R A04C.R L A04C.L
▼ ØDmin (Min. Bohrung) // ØDmin (min. bore) = 3,0 mm														
4,0	0,7	8,1	3,0	●	A04.0070.08.30 GR/L	R APXM L AD4E	X800 X400	2,75	1,95	1,35	13,0	-	0,6	R A04.R L A04.L
4,0	0,7	8,1	3,0	+	A04.C070.08.30 GR/L	R AM07 L AMXM	X800 X400	2,75	1,95	1,95	13,0	-	0,6	R A04C.R L A04C.L
4,0	0,7	12,2	3,0	●	A04.0070.12.30 GR/L	R ACVH L ANXB	X800 X400	2,75	1,95	1,35	18,0	-	0,6	R A04.R L A04.L
4,0	0,7	12,2	3,0	+	A04.C070.12.30 GR/L	R ACKP L ANQE	X800 X400	2,75	1,95	1,95	18,0	-	0,6	R A04C.R L A04C.L
4,0	0,7	16,3	3,0	●	A04.0070.16.30 GR/L	R ADVD L AEHC	X800 X400	2,75	1,95	1,35	23,0	-	0,6	R A04.R L A04.L
4,0	0,7	16,3	3,0	+	A04.C070.16.30 GR/L	R AB70 L ANVK	X800 X400	2,75	1,95	1,95	23,0	-	0,6	R A04C.R L A04C.L
▼ ØDmin (Min. Bohrung) // ØDmin (min. bore) = 4,2 mm														
4,0	0,787	10,2	4,2	+	A04.0078.10.42 GR/L	R AFQB L AHW7	X800 X400	3,95	2,95	1,95	13,0	-	0,8	R A04C.R L A04C.L
4,0	0,787	15,2	4,2	+	A04.0078.15.42 GR/L	R AJGY L AFP6	X800 X400	3,95	2,95	1,95	18,0	-	0,8	R A04C.R L A04C.L
4,0	0,787	20,3	4,2	+	A04.0078.20.42 GR/L	R AKJA L AD5G	X800 X400	3,95	2,95	1,95	23,0	-	0,8	R A04C.R L A04C.L
4,0	0,787	25,4	4,2	+	A04.0078.25.42 GR/L	R APCB L AMMY	X800 X400	3,95	2,95	1,95	28,0	-	0,8	R A04C.R L A04C.L
4,0	1,0	10,2	4,2	+	A04.0100.10.42 GR/L	R ANMY L AACT	X800 X400	3,95	2,95	1,95	13,0	-	0,8	R A04C.R L A04C.L
4,0	1,0	15,2	4,2	+	A04.0100.15.42 GR/L	R AAQT L AGWU	X800 X400	3,95	2,95	1,95	18,0	-	0,8	R A04C.R L A04C.L
4,0	1,0	20,3	4,2	+	A04.0100.20.42 GR/L	R ABMQ L AF0K	X800 X400	3,95	2,95	1,95	23,0	-	0,8	R A04C.R L A04C.L

Verwandte Werkzeuge finden Sie auch auf der folgenden Seite!
Related Items can be found on the following page as well!

Fortgesetzte Tabelle
Continued Table

Bestellbeispiel // Order example: A04.0100.10.42 GR X800 (R = Rechte Ausführung // Right hand version, X800 = Schneidstoff // Grade)