

Klemmhalter, Innenbearbeitung, Rundschaft

Rundschaft mit innerer Kühlmittelzufuhr für die Größe A05.

Toolholder, Internal Applications, Round Shank

Round shank with through coolant for size A05.

Anzugsmoment (Schraube) // Tightening torque (screw)

7,0 Nm

Bitte Hinweise im Anhang beachten // Please read add. notes

MASTER (Seite/Page 137)



Legende
Legend

139



Scan
QR-Code

Oder besuchen Sie // Or Visit
www.simtek.info/cp/782

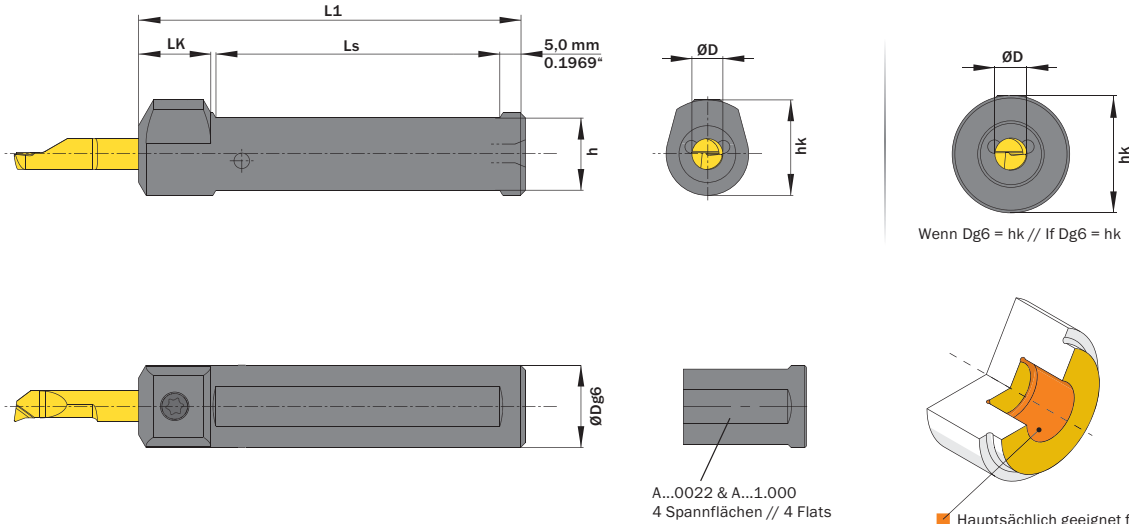

- Hauptsächlich geeignet für diese Flächen
Mainly designed for these surfaces
- Je nach Schneidplatte ebenfalls möglich
Also possible depending on insert type

ØD	ØDg6	Artikelnummer Part number	Webcode www.simtek.com/webcode	h	hk	L1	LK	Ls	Anzahl Spannflächen Number of flats	Schraube Screw	Schraubenschlüssel Screw driver	Connectcode www.simtek.com/code
mm	mm			mm	mm	mm	mm	mm				

Fortgesetzte Tabelle
Continued Table

Verwandte Werkzeuge finden Sie auch auf der vorhergehenden Seite!
Related items can be found on the previous page as well!

5,0	10,0	A05.0010	ABMY	8,0	15,0	65,0	14,0	45,0	2	A M6x7,5 T15F	T15F	A05.L A05.R
5,0	12,0	A05.0012	AEA9	10,0	16,0	70,0	14,0	50,0	2	A M6x7,5 T15F	T15F	A05.L A05.R
5,0	12,7	A05.0.500	AHQV	10,7	16,35	70,0	14,0	50,0	2	A M6x7,5 T15F	T15F	A05.L A05.R inch
5,0	15,875	A05.0.625	AGG2	13,88	17,94	75,0	14,0	55,0	2	A M6x7,5 T15F	T15F	A05.L A05.R inch
5,0	16,0	A05.0016	AEGF	14,0	18,0	75,0	14,0	55,0	2	A M6x7,5 T15F	T15F	A05.L A05.R
5,0	19,05	A05.0.750	AAF8	17,05	19,05	110,0	14,0	90,0	2	A M6x7,5 T15F	T15F	A05.L A05.R inch
5,0	20,0	A05.0020	ABDK	18,0	20,0	90,0	14,0	70,0	2	A M6x7,5 T15F	T15F	A05.L A05.R
5,0	22,0	A05.0022	AG78	20,0	22,0	110,0	-	90,0	4	A M6x7,5 T15F	T15F	A05.L A05.R
5,0	23,0	A05.0023	AGZX	21,0	23,0	110,0	-	90,0	2	A M6x7,5 T15F	T15F	A05.L A05.R
5,0	25,0	A05.0025	AMVA	23,0	25,0	110,0	-	90,0	2	A M6x7,5 T15F	T15F	A05.L A05.R
5,0	25,4	A05.1.000	AMM2	23,4	25,4	110,0	-	90,0	4	A M6x7,5 T15F	T15F	A05.L A05.R inch

Verwandte Werkzeuge finden Sie auch auf der folgenden Seite!
Related items can be found on the following page as well!

Fortgesetzte Tabelle
Continued Table

Bestellbeispiel // Order example: **A05.0016**