

# Klemmhalter, Innenbearbeitung

Schwingungsgedämpfter Hartmetall-Rundschaft mit innerer Kühlmittelzufuhr.

## Toolholder, For Internal Applications

Anti-vibration solid carbide round shank toolholder with through coolant.

Anzugsmoment (Schraube) // Tightening torque (screw)

**7,0 Nm**

Bitte Hinweise im Anhang beachten // Please read add. notes

**MASTER (Seite/Page 212)**



Legende  
Legend **213**

Scan  
QR-Code

Oder besuchen Sie // Or Visit  
[www.simtek.info/cp/957](http://www.simtek.info/cp/957)

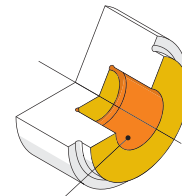
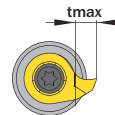
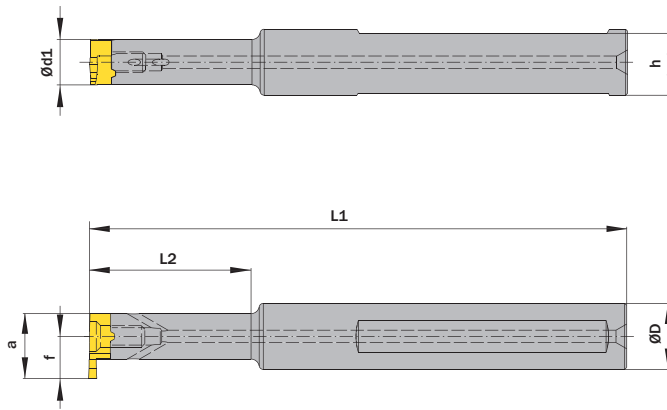

Maße „a“, „f“ und „tmax“ sind abhängig vom verwendeten Schneideinsatz.  
Dimensions „a“, „f“ and „tmax“ depend on used carbide inserts.

Abbildung zeigt / Drawing shows: D16.0016.40 HM

- Hauptsächlich geeignet für diese Flächen  
Mainly designed for these surfaces
- Je nach Schneidplatte ebenfalls möglich  
Also possible depending on insert type

Ød <sup>h6</sup>	L2	Artikelnummer Part number	Webcode <a href="http://www.simtek.com/webcode">www.simtek.com/webcode</a>	Ød1	h	L1	Schraube Screw	Schraubenschlüssel Screw driver	Connectcode <a href="http://www.simtek.com/code">www.simtek.com/code</a>
mm	mm			mm	mm	mm			

Fortgesetzte Tabelle  
Continued Table

Verwandte Werkzeuge finden Sie auch auf der vorhergehenden Seite!  
Related items can be found on the previous page as well!

▼ ØD = 12,0 mm									
12,0	40,0	<b>D16.0012.40 HM</b>	AESE	11,0	11,0	130,0	D M5x12 T20T	T20T	D16
12,0	56,0	<b>D16.0012.56 HM</b>	ABY7	11,0	11,0	130,0	D M5x12 T20T	T20T	D16
12,0	80,0	<b>D16.0012.80 HM</b>	AAYX	11,0	11,0	150,0	D M5x12 T20T	T20T	D16
▼ ØD = 12,7 mm									
12,7	40,0	<b>D16.0.500.40 HM</b>	AK10	11,0	11,7	130,0	D M5x12 T20T	T20T	D16 <small>inch</small>
12,7	56,0	<b>D16.0.500.56 HM</b>	AKTU	11,0	11,7	130,0	D M5x12 T20T	T20T	D16 <small>inch</small>
12,7	80,0	<b>D16.0.500.80 HM</b>	APXA	11,0	11,7	150,0	D M5x12 T20T	T20T	D16 <small>inch</small>
▼ ØD = 15,875 mm									
15,875	40,0	<b>D16.0.625.40 HM</b>	APM8	11,0	14,88	130,0	D M5x12 T20T	T20T	D16 <small>inch</small>
15,875	56,0	<b>D16.0.625.56 HM</b>	ADJ3	11,0	14,88	130,0	D M5x12 T20T	T20T	D16 <small>inch</small>
15,875	80,0	<b>D16.0.625.80 HM</b>	AFSY	11,0	14,88	150,0	D M5x12 T20T	T20T	D16 <small>inch</small>
▼ ØD = 16,0 mm									
16,0	40,0	<b>D16.0016.40 HM</b>	ACA6	11,0	15,0	130,0	D M5x12 T20T	T20T	D16
16,0	56,0	<b>D16.0016.56 HM</b>	ABJH	11,0	15,0	130,0	D M5x12 T20T	T20T	D16
16,0	80,0	<b>D16.0016.80 HM</b>	AEF9	11,0	15,0	150,0	D M5x12 T20T	T20T	D16

Verwandte Werkzeuge finden Sie auch auf der folgenden Seite!  
Related items can be found on the following page as well!

Fortgesetzte Tabelle  
Continued Table

Bestellbeispiel // Order example: **D16.0016.40 HM**