

Einstecken und Profildrehen

CNC-Feindrehen.

Grooving and Profiling

CNC profiling.

Schnittwerte (Start) // Cutting parameters (start)

f	Vc
0,04 mm/U	Seite/Page 429

Passende Klemmhalter auf Seite // Suitable toolholders on page
361, 362, 363, 364, 365, 367, 368



SP SP
 CBN HM
 Legende Legend **389**

Scan QR-Code Oder besuchen Sie // Or Visit
www.simtek.info/cp/506



Abbildung zeigt / Drawing shows: E12.0300.06 N

w ^{+0,03} mm	R mm	Artikelnummer Part number	Webcode www.simtek.com/webcode	Unsere erste Wahl Our first choice P K M N S	Connectcode www.simtek.com/code
▼ w = 1,0 mm					
1,0	0,05	E12.0100.00 N	AMFH	X800 X400	E12.A1 E12.A2
1,0	0,2	E12.0100.02 N	AP31	X800 X400	E12.A1 E12.A2
▼ w = 1,5 mm					
1,5	0,05	E12.0150.00 N	AKVM	X800 X400	E12.A1 E12.A2
1,5	0,2	E12.0150.02 N	AEWQ	X800 X400	E12.A1 E12.A2
▼ w = 2,0 mm					
2,0	0,05	E12.0200.00 N	AEVK	X800 X400	E12.A1 E12.A2
2,0	0,2	E12.0200.02 N	AB41	X800 X400	E12.A1 E12.A2
2,0	0,4	E12.0200.04 N	AFS9	X800 X400	E12.A1 E12.A2
▼ w = 2,5 mm					
2,5	0,05	E12.0250.00 N	AG51	X800 X400	E12.A2 E12.B2
2,5	0,2	E12.0250.02 N	AGZ8	X800 X400	E12.A2 E12.B2
2,5	0,4	E12.0250.04 N	AECQ	X800 X400	E12.A2 E12.B2

Verwandte Werkzeuge finden Sie auch auf der folgenden Seite!
 Related Items can be found on the following page as well!

Fortgesetzte Tabelle
 Continued Table

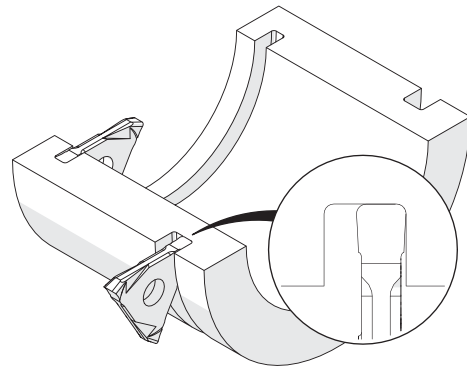
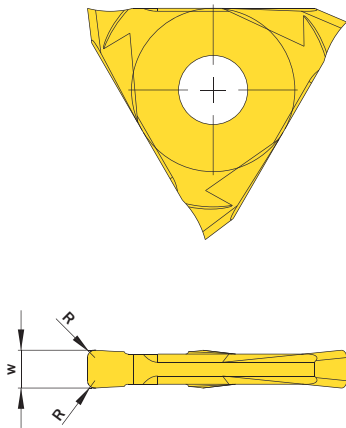
Bestellbeispiel // Order example: **E12.0100.00 N X800** (X800 = Schneidstoff // Grade)



E12. w, 1/100 mm, 4 Stellen/Digits . R, 1/100 mm, 3 Stellen/Digits Toleranz // Tolerance
 Beispielartikelnummer // Example Part number: **E12.0156.015 XN**