

Stechen, Sicherungsringnuten

Sicherungsringnuten, vgl. DIN 471/472 sowie DIN 983/984.

Grooving, Circlip Ring Grooves

Circlip ring grooves comp. to DIN 471/472 and DIN 983/984.

Schnittwerte (Start) // Cutting parameters (start)

f	Vc
0,04 mm/U	Seite/Page 429

Passende Klemmhalter auf Seite // Suitable toolholders on page

361, 362, 363, 364, 365, 367, 368



SP Legende
HM Legend

389



Scan QR-Code Oder besuchen Sie // Or Visit www.simtek.info/cp/500



Abbildung zeigt / Drawing shows: E12.0265.00 G

Nennbreite Nominal width of groove mm	Artikelnummer Part number	Webcode www.simtek.com/webcode	Unsere erste Wahl Our first choice	w ^{+0,03} mm		Connectcode www.simtek.com/ccode
				P	K M N S	
1,1	E12.0110.00 G	AN0Z	X800 X400		1,2	E12.A1 E12.A2
1,3	E12.0130.00 G	AG7C	X800 X400		1,4	E12.A1 E12.A2
1,6	E12.0160.00 G	AE2Y	X800 X400		1,7	E12.A1 E12.A2
1,85	E12.0185.00 G	AMUJ	X800 X400		1,95	E12.A1 E12.A2
2,15	E12.0215.00 G	ANBG	X800 X400		2,25	E12.A2 E12.B2
2,65	E12.0265.00 G	AKPW	X800 X400		2,75	E12.B2
3,15	E12.0315.00 G	AFFJ	X800 X400		3,25	E12.C3
4,15	E12.0415.00 G	AEBD	X800 X400		4,25	E12.D4
5,15	E12.0515.00 G	AJMV	X800 X400		5,25	E12.D4

Bestellbeispiel // Order example: **E12.0110.00 G X800** (X800 = Schneidstoff // Grade)

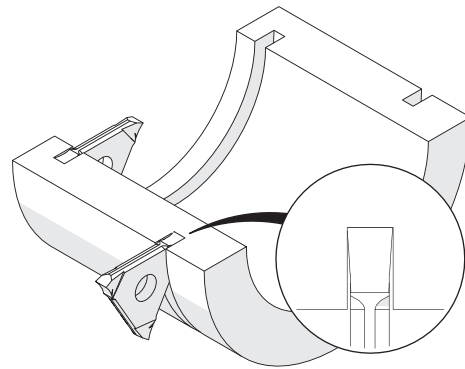
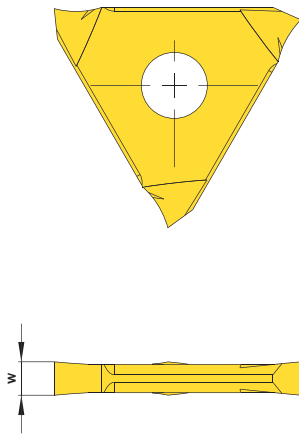

E12. **w, 1/100 mm, 4 Stellen/Digits** . **R, 1/100 mm, 3 Stellen/Digits** **Toleranz // Tolerance**
 Beispielartikelnummer // Example Part number: **E12.0156.015 XN**

simturn AX
 simturn DX
 simturn PX
 simturn H2
 simturn K2
 simturn C4
 simturn GX
 simturn E3
 simturn E12
 simturn FX
 simturn Decolletage
 simturn OA
 Index