

Stechen, Sicherungsringnuten, mit geschliffener Spanformrille

Sicherungsringnuten, vgl. DIN 471/472 sowie DIN 983/984. Mit geschliffener Spanformrille.

Grooving, Circlip Ring Grooves, With Ground Chip Form Channel

Circlip ring grooves comp. to DIN 471/472 and DIN 983/984. With ground chip form channel.

Schnittwerte (Start) // Cutting parameters (start)

f	Vc
0,08 mm/U	Seite/Page 429

Passende Klemmhalter auf Seite // Suitable toolholders on page

361, 362, 363, 364, 365, 367, 368



SP Legende
HM Legend

389

Scan QR-Code

Oder besuchen Sie // Or Visit www.simtek.info/cp/503



Abbildung zeigt / Drawing shows: E12.0265.11 K

Nennbreite Nominal width of groove	Artikelnummer Part number	Webcode www.simtek.com/webcode	Unsere erste Wahl Our first choice	w ^{+0,03}		Connectcode www.simtek.com/ccode
				mm	mm	
1,1	E12.0110.11 K	AJBT	X800 X400	1,2		E12.A1 E12.A2
1,3	E12.0130.11 K	AJJ3	X800 X400	1,4		E12.A1 E12.A2
1,6	E12.0160.11 K	ACKU	X800 X400	1,7		E12.A1 E12.A2
1,85	E12.0185.11 K	AK7B	X800 X400	1,95		E12.A1 E12.A2
2,15	E12.0215.11 K	AH5U	X800 X400	2,25		E12.A2 E12.B2
2,65	E12.0265.11 K	AH76	X800 X400	2,75		E12.B2
3,15	E12.0315.11 K	AE79	X800 X400	3,25		E12.C3

Bestellbeispiel // Order example: **E12.0185.11 K X800** (X800 = Schneidstoff // Grade)

simturn AX

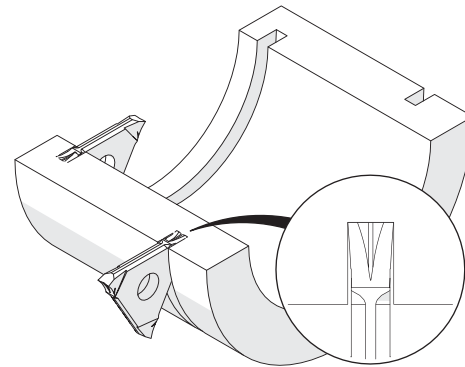
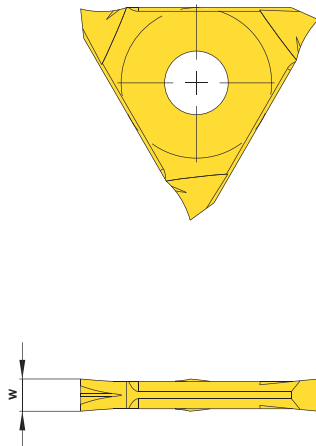
simturn DX

simturn PX

simturn H2

simturn K2

simturn C4

simturn GX

simturn E3

simturn E12

simturn FX

simturn Decolletage

simturn OA

Index