

Stechen von Vollradiusnuten

Geeignet ab Bohrungsdurchmesser 4,2 mm.

Full Radius Grooving

For use in bores as of minimum bore diameter 4,2 mm.

Schnittwerte (Start) // Cutting parameters (start)	
f 0,02 mm/U	Vc Seite/Page 429

Passende Klemmhalter auf Seite // Suitable toolholders on page	
29, 31, 37, 42, 46, 52, 54, 56, 58, 61, 64, 65, 66, 67, 68, 69	

SP

HM

R

Legende
Legend **139**

Scan
QR-Code

Oder besuchen Sie // Or Visit
www.simtek.info/cp/1391



Abbildung zeigt / Drawing shows: A06.0150.25.62 VR

Mehr Informationen zur Kühlmittelzufuhr finden Sie auf Seite 22
Additional information about through coolant supply on page 22

ØD	w ^{+0,03}	L2	ØDmin (Min. Bohrung) ØDmin (min. bore)	Kühlmittelzufuhr Through coolant supply	Artikelnummer Part number	Webcode www.simtek.com/webcode	Unsere erste Wahl Our first choice	a	d	f	LH	R	tmax	Connectcode www.simtek.com/code
mm	mm	mm	mm				P K M N S	mm	mm	mm	mm	mm	mm	

Fortgesetzte Tabelle
Continued Table

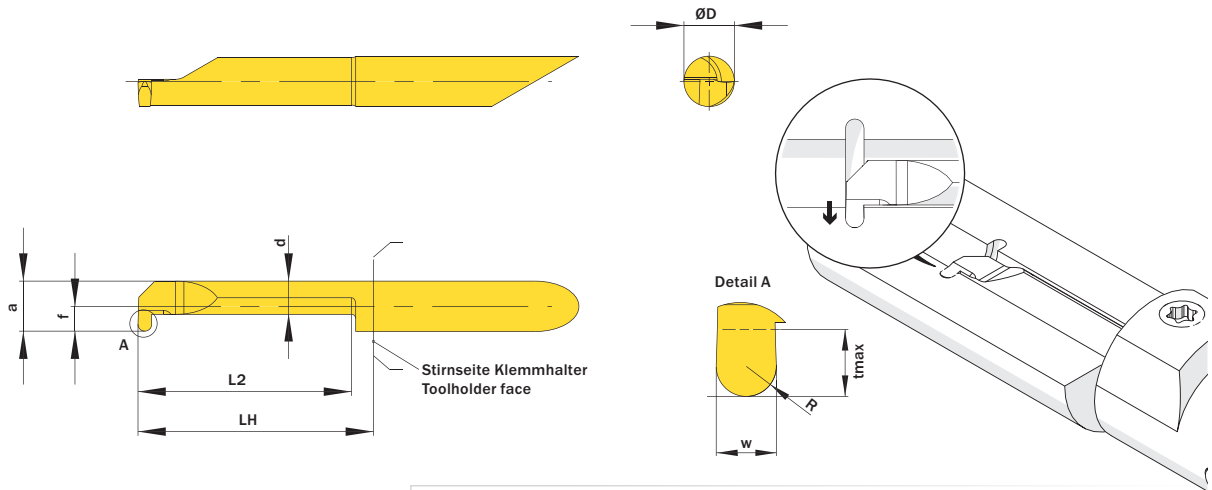
Verwandte Werkzeuge finden Sie auch auf der vorhergehenden Seite!
Related items can be found on the previous page as well!

7,0	1,0	30,5	7,2	+	A07.0100.30.72 VR/L	R AMUA L APBC	X800 X400	6,95	4,25	3,45	33,0	0,5	2,5	R A07.R L A07.L	
7,0	1,168	30,5	7,2	+	A07.0117.30.72 VR/L	R ABU4 L AETJ	X800 X400	6,95	4,25	3,45	33,0	0,58	2,5	R A07.R L A07.L	inch
7,0	1,5	30,5	7,2	+	A07.0150.30.72 VR/L	R AJX4 L AJG8	X800 X400	6,95	4,25	3,45	33,0	0,75	2,5	R A07.R L A07.L	
7,0	1,575	30,5	7,2	+	A07.0157.30.72 VR/L	R AG9X L AE47	X800 X400	6,95	4,25	3,45	33,0	0,79	2,5	R A07.R L A07.L	inch
7,0	1,626	30,5	7,2	+	A07.0163.30.72 VR	A4N1	X800 X400	6,95	4,25	3,45	33,0	0,81	2,5	A07.R	new inch
7,0	1,981	30,5	7,2	+	A07.0198.30.72 VR/L	R AT8S L AT8Q	X800 X400	6,95	4,25	3,45	33,0	0,99	2,5	R A07.R L A07.L	inch
7,0	2,0	30,5	7,2	+	A07.0200.30.72 VR/L	R ACTT L ACE9	X800 X400	6,95	4,25	3,45	33,0	1,0	2,5	R A07.R L A07.L	

Bestellbeispiel // Order example: **A07.0100.30.72 VR X800** (R = Rechte Ausführung // Right hand version, X800 = Schneidstoff // Grade)