

Axialstechen

Für die Herstellung von Axialnuten.
 Bitte beachten Sie die Freiwinkel.

Face Grooving

For face grooves in different widths.
 Please pay attention to the clearance angles.

Schnittwerte (Start) // Cutting parameters (start)

f (außen//ext.) 0,04 mm/U	Vc Seite/Page 429
------------------------------	----------------------

Passende Klemmhalter auf Seite // Suitable toolholders on page
323, 324, 325, 326, 327, 328

SP
HM

L

○

Legende
Legend **354**

Scan
QR-Code Oder besuchen Sie // Or Visit
www.simtek.info/cp/328

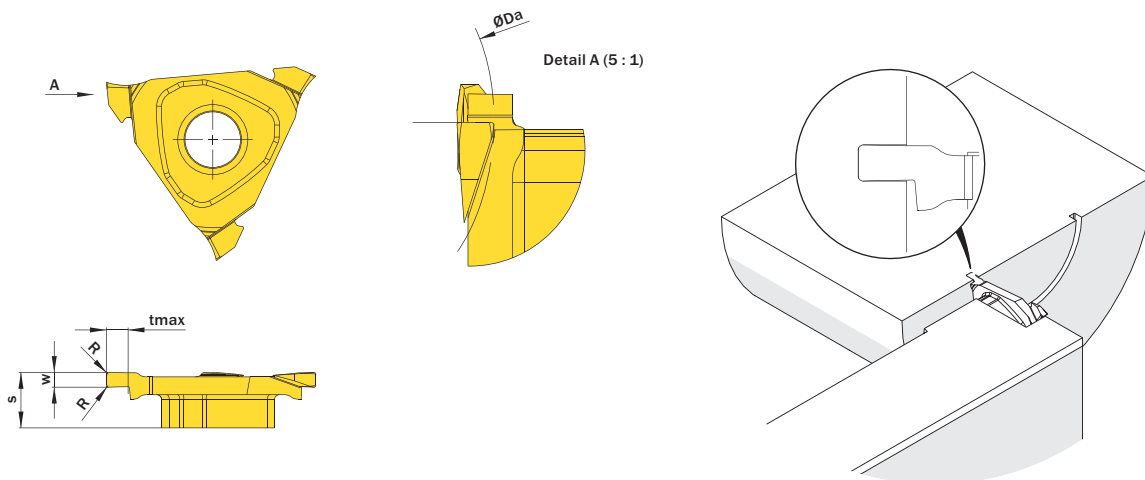

Abbildung zeigt / Drawing shows: TE3.R150.020 AG L

w ±0,02 mm	R mm	Artikelnummer Part number	Webcode www.simtek.com/webcode	Unsere erste Wahl Our first choice	ØDa mm	S mm	tmax mm	Connectcode www.simtek.com/ccode
1,5	0,2	TE3.R150.020 AG L	AE96	P K M N S X800 X400	20,0	5,6	2,0	TE3.L.5.3
2,0	0,2	TE3.R200.020 AG L	ADYQ	P K M N S X800 X400	30,0	5,6	3,0	TE3.L.5.3
3,0	0,2	TE3.R300.020 AG L	APTH	P K M N S X800 X400	30,0	5,6	3,0	TE3.L.5.3

Bestellbeispiel // Order example: **TE3.R200.020 AG L X800** (L = Linke Ausführung // Left hand version, X800 = Schneidstoff // Grade)