

# Stechdrehen, Sicherungsringnuten mit Fassung

Sicherungsringnuten vgl. DIN 471/472 sowie DIN 983/984, mit Nutaußenkantenfasung.

# Grooving, Circlip Ring Grooves with Chamfer

Circlip ring grooves comp. to DIN 471/472 and DIN 983/984, with chamfer.

Schnittwerte (Start) // Cutting parameters (start)		
f (außen//ext.) 0,04 mm/U	f (innen//int.) 0,03 mm/U	Vc Seite/Page 429

Passende Klemmhalter auf Seite // Suitable toolholders on page  
**323, 324, 325, 326, 327, 328**

SP

HM

R

Legende  
 Legend **354**

Oder besuchen Sie // Or Visit  
[www.simtek.info/cp/332](http://www.simtek.info/cp/332)

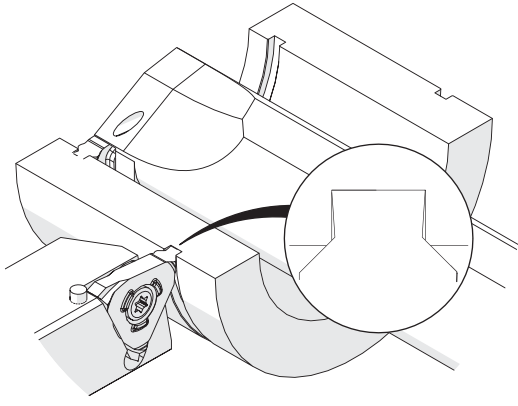
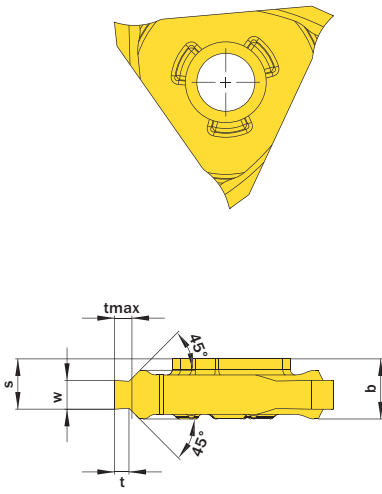

Abbildung zeigt / Drawing shows: TE3.2616.00 F R

Nutnenbreite Nominal width of groove	w <sup>+0,03</sup>	Artikelnummer Part number	Webcode www.simtek.com/webcode	Unsere erste Wahl Our first choice	b	s	t	tmax	Connectcode www.simtek.com/code	
										P
▼ Nutnenbreite // Nominal width of groove = 1,1 mm										
1,1	1,2	<b>TE3.1105.00 F R/L</b>	R AFC9 L AN28	X800 X400	5,8	5,37	0,36	0,4	R TE3.R.5.3 L TE3.L.5.3	
▼ Nutnenbreite // Nominal width of groove = 1,3 mm										
1,3	1,4	<b>TE3.1306.00 F R/L</b>	R AEQZ L AMVQ	X800 X400	5,8	5,47	0,45	0,55	R TE3.R.5.3 L TE3.L.5.3	
▼ Nutnenbreite // Nominal width of groove = 1,6 mm										
1,6	1,7	<b>TE3.1607.00 F R/L</b>	R AACQ L APPJ	X800 X400	5,8	5,49	0,6	0,7	R TE3.R.5.3 L TE3.L.5.3	
1,6	1,7	<b>TE3.1608.00 F R/L</b>	R AK00 L ABUB	X800 X400	5,8	5,49	0,75	0,85	R TE3.R.5.3 L TE3.L.5.3	
1,6	1,7	<b>TE3.1609.00 F R/L</b>	R AJ0M L ANCC	X800 X400	5,8	5,49	0,85	1,0	R TE3.R.5.3 L TE3.L.5.3	
▼ Nutnenbreite // Nominal width of groove = 1,85 mm										
1,85	1,95	<b>TE3.1810.00 F R/L</b>	R ACD6 L ANG2	X800 X400	5,8	5,47	0,85	1,0	R TE3.R.5.3 L TE3.L.5.3	
1,85	1,95	<b>TE3.1812.00 F R/L</b>	R ABE7 L AG5M	X800 X400	5,8	5,47	1,1	1,25	R TE3.R.5.3 L TE3.L.5.3	
▼ Nutnenbreite // Nominal width of groove = 2,15 mm										
2,15	2,25	<b>TE3.2115.00 F R/L</b>	R AB8G L AGPQ	X800 X400	5,8	5,17	1,35	1,5	R TE3.R.5.3 L TE3.L.5.3	
▼ Nutnenbreite // Nominal width of groove = 2,65 mm										
2,65	2,75	<b>TE3.2616.00 F R/L</b>	R ADY6 L ANB3	X800 X400	5,8	5,37	1,35	1,5	R TE3.R.5.3 L TE3.L.5.3	
2,65	2,75	<b>TE3.2617.00 F R/L</b>	R ACFT L APV8	X800 X400	5,8	5,37	1,6	1,75	R TE3.R.5.3 L TE3.L.5.3	
▼ Nutnenbreite // Nominal width of groove = 3,15 mm										
3,15	3,25	<b>TE3.3118.00 F R/L</b>	R AC3K L AKVF	X800 X400	5,8	5,12	1,6	1,75	R TE3.R.5.3 L TE3.L.5.3	
▼ Nutnenbreite // Nominal width of groove = 4,15 mm										
4,15	4,25	<b>TE3.4120.00 F R/L</b>	R AAGD L AAGN	X800 X400	5,8	5,12	1,85	2,0	R TE3.R.5.3 L TE3.L.5.3	
4,15	4,25	<b>TE3.4125.00 F R/L</b>	R AFPP L APTT	X800 X400	5,8	5,12	2,35	2,5	R TE3.R.5.3 L TE3.L.5.3	
▼ Nutnenbreite // Nominal width of groove = 5,15 mm										
5,15	5,25	<b>TE3.5130.00 F R/L</b>	R ADWB L AF7M	X800 X400	6,6	5,82	2,85	3,0	R TE3.R.5.3 L TE3.L.5.3	

Bestellbeispiel // Order example: **TE3.2115.00 F R X800** (R = Rechte Ausführung // Right hand version, X800 = Schneidstoff // Grade)

simturn AX  
simturn DX  
simturn PX  
simturn H2  
simturn K2  
simturn C4  
simturn GX  
simturn E3  
simturn E12  
simturn FX  
simturn Decolletage  
simturn OA  
Index