

Einstecken und Profildrehen, Vollradius

Vollradiusnuten, CNC-Konturdrehen.

Grooving and Profiling, Full Radius

Full radius, CNC profiling.

Schnittwerte (Start) // Cutting parameters (start)

f	Vc
0,04 mm/U	Seite/Page 429

Passende Klemmhalter auf Seite // Suitable toolholders on page

361, 362, 363, 364, 365, 367, 368



SP Legende
HM Legend

389

Scan QR-Code

Oder besuchen Sie // Or Visit
www.simtek.info/cp/507

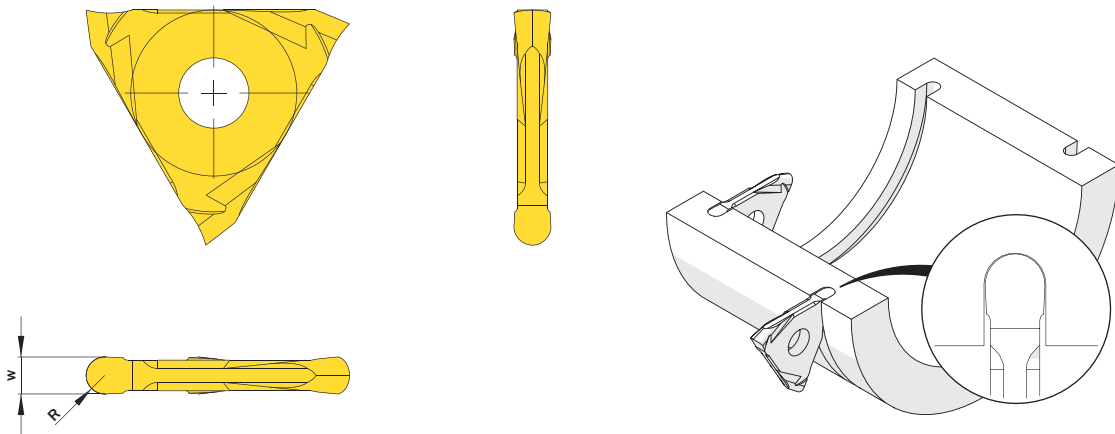

Abbildung zeigt / Drawing shows: E12.0300.15 V

w ^{+0,04} mm	R mm	Artikelnummer Part number	Webcode www.simtek.com/webcode	Unsere erste Wahl Our first choice		Connectcode www.simtek.com/ccode
				P	K	
1,0	0,5	E12.0100.05 V	ADKV	X800	X400	E12.A1 E12.A2
1,2	0,6	E12.0120.06 V	AKTC	X800	X400	E12.A1 E12.A2
1,5	0,75	E12.0150.07 V	AMYT	X800	X400	E12.A1 E12.A2
2,0	1,0	E12.0200.10 V	AFZA	X800	X400	E12.A1 E12.A2
2,38	1,19	E12.0238.12 V	A1PG	X800	X400	E12.A1 E12.A2
2,5	1,25	E12.0250.12 V	AH44	X800	X400	E12.A2 E12.B2
3,0	1,5	E12.0300.15 V	AAW2	X800	X400	E12.B2
4,0	2,0	E12.0400.20 V	AFGY	X800	X400	E12.C3

Bestellbeispiel // Order example: **E12.0150.07 V X800** (X800 = Schneidstoff // Grade)

simturn AX
 simturn DX
 simturn PX
 simturn H2
 simturn K2
 simturn C4
 simturn GX
 simturn E3
 simturn E12
 simturn FX
 simturn Decolletage
 simturn OA
 Index